

# Ultra small size Adjustable output high voltage power supply 2.5W to 3W Mid-high voltage DC-DC converter

## Bellnix®

# 0V to 180V, 300V, 350V MHV Series

The MHV series is the first high voltage power supply in the industry to use the latest SMT (surface mount technology) making the size 1/5 to 1/6 of the normal product, with an adjustable output voltage type mid-high voltage DC-DC converter. Output voltage can be controlled using an external voltage or external resistor. The MHV series has adopted a 5 sided metallic shield, with lower ripple and lower noise.

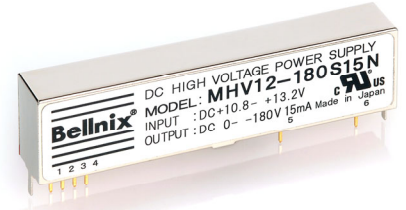

### Features

- PCB mounting type
- Output capacity 2.5W to 3W
- Over current protection
- Worlds smallest size
- Low price
- UL certified product (UL File No. E305960)
- Adopted a 5 sided metallic shield case
- 100% Burn in test
- Adjustable voltage using an external voltage
- Low ripple noise of 30mVp-p
- High reliability, long life

### Model/Rating

Model name MHV Series	Input voltage (Vdc)	Output voltage (Vdc) Note1	Output current (mA)	Load resistor (k $\Omega$ ) min	Output capacity (W)	Input current (mA) typ	Ripple noise (mVp-p) typ	Case
MHV12-180S15P	10.8 to 13.2	0 to +180	0 to 15	12	2.7	350	30	M-8
MHV12-180S15N	10.8 to 13.2	0 to -180	0 to 15	12	2.7	350	30	M-8
MHV12-300S10P	10.8 to 13.2	0 to +300	0 to 10	30	3.0	395	30	M-8
MHV12-300S10N	10.8 to 13.2	0 to -300	0 to 10	30	3.0	395	30	M-8
MHV12-350S07P	10.8 to 13.2	0 to +350	0 to 7	50	2.5	330	30	M-8
MHV12-350S07N	10.8 to 13.2	0 to -350	0 to 7	50	2.5	330	30	M-8

### Specifications

Line regulation	0.02% typ.(Input current varying from +10.8V to +13.2V)
Load regulation	180V type : 0.5% typ. 300V, 350V type : 0.2% typ.(Load current varying from 0% to 100%)
Temp regulation	$\pm 0.01\%$ typ.(Temp varying from -10 to +50 )
Over current protection	Letter $\nabla$ characteristic, auto restart circuit at 105% or more
Output voltage accuracy	Below $\pm 5\%$ (Rated output, rated load, and Vcont=4.0V)
Output voltage control	External voltage 0V to +4V or an external resistor 5K $\Omega$ to adjust
Usage temp range	-10 to +60 (Derating required for temp higher than +50 )
Storage temp range	-25 to +85
Usage humidity range	20% to 95%RH(no dewing)
Isolation between input/output	Non isolated type (2pin-5pin and the case are connected internally)
MTBF expected value	480,000H min. (Bellnix MTBF formula diagram)

Note1: The output voltage will be controlled by applying the Vcont voltage. Using an adjustable resistor or an external voltage, voltage should be applied on the Vcont pin in order to control the output voltage. When Vcont voltage=0V the output voltage (output residual voltage) should be less than 0.5% of the max output voltage(I/O rated).

### Test circuit

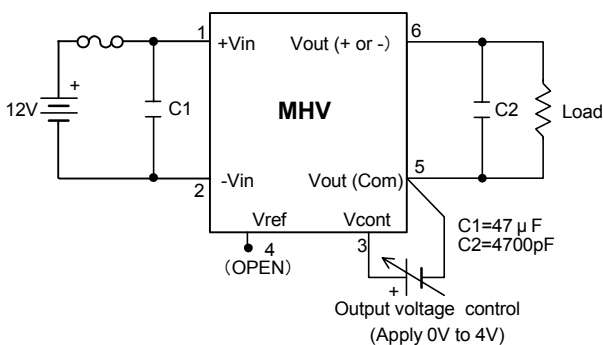

Warning1: The ground line (2pin, 5pin) between the input/output, and the case are internally connected. Warning2: Vref is 4V  $\pm$  0.3V (When external VR=5K $\Omega$ )

### Block diagram

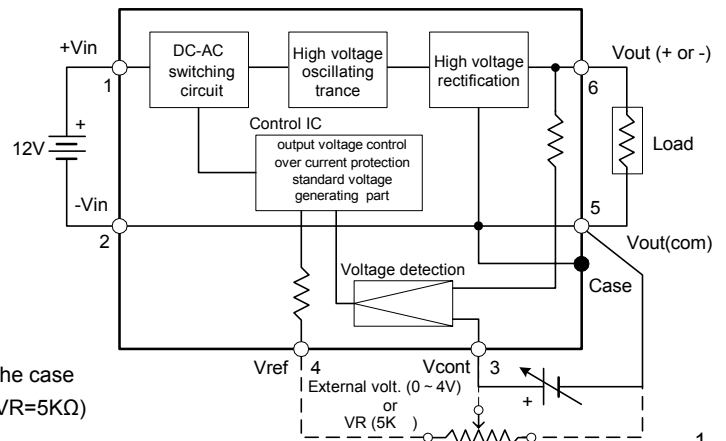

Model/Dimensions/Pin configuration (M-8 case)

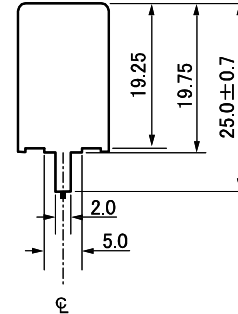
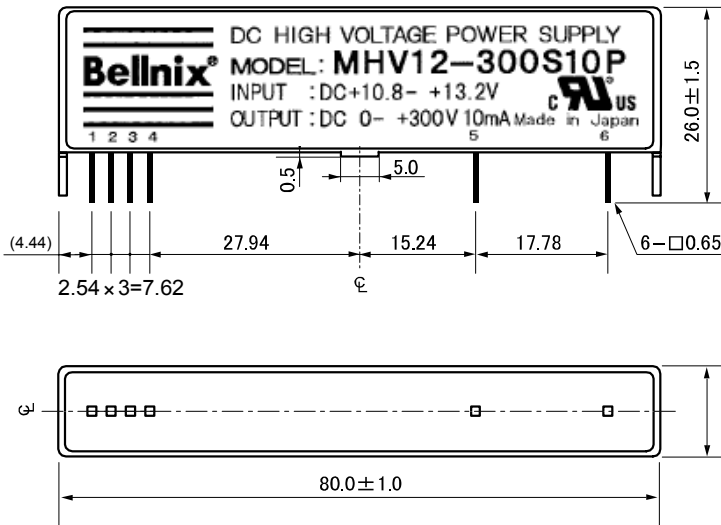

pin-NO.	pin name
1	+Vin
2	-Vin
3	Vcont
4	Vref
5	Vout (com)
6	Vout (+ or -)

1)Pin

Material : Phosphorous bronze  
Treatment : Ni base Au coating

2)Case

Material : Brass  
Treatment : Nickel coating

Weight : 46g typ.  
Unit : mm  
Tolerances unless  
otherwise specified:±0.5

**Standard usage instructions**

MHV Series (180V, 300V, 350V)

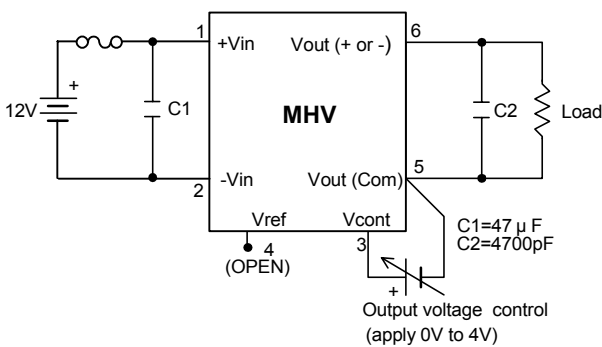

The MHV series does not require any external parts, however when the impedance is high, for example: the distance between the power supply and converter is long, the input line is thin, or the input side has a filter then connecting a capacitor C1 to the input side is recommended.

Place the capacitor as close as possible to the converter pin side, to lower the lead inductance.

**Over current protection**

The MHV series has a over load and load short protection installed, which is the over current protection. When the product status is in over load or load short mode, the output voltage will decrease, and once the problem has been removed, the voltage will increase again.

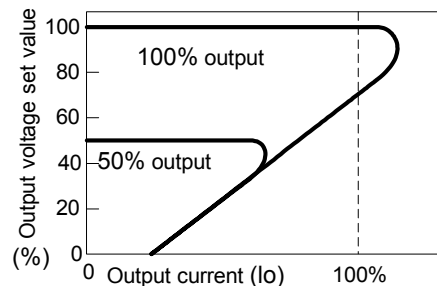

MHV series  
Over current protection  
characteristic

## Recommended pin pattern

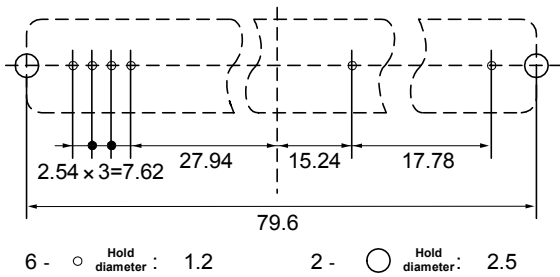

The MHV series uses a metallic case. When soldering to a double-sided PCB, the wiring for the converter should be on the soldering side.

Also, this converter will generate high voltages so the creepage distance should also be taken into account when designing.

When mounting to a double-sided PCB, the high voltage output pin and land should be as small as possible.

The MHV series case should be connected to the -Vin and Vout (Com).

The metallic case does not need to be touching anything. However, when using and making contact with the metallic case, the anti land impedance should be lowered.

## Vref pin (standard voltage output)

When controlling the output voltage with an adjustable resistor, this pin is used. Vref has a standard output voltage of 4V. In this case, the external adjustable resistor is 5K $\Omega$ . Since the resistance value from the external adjustable resistor will decide the output voltage with the effect of the specified value, use a resistance value with an accuracy of 5K $\Omega$  $\pm$ 5%. The type of resistor does not matter, as long as it is 5K $\Omega$ , however one with a good temp coefficient is recommended.

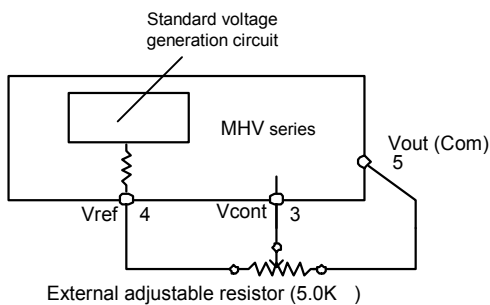

## Setting output voltage and adjusting feature

The MHV series output voltage can be adjusted by using an external voltage or external adjustable resistor.

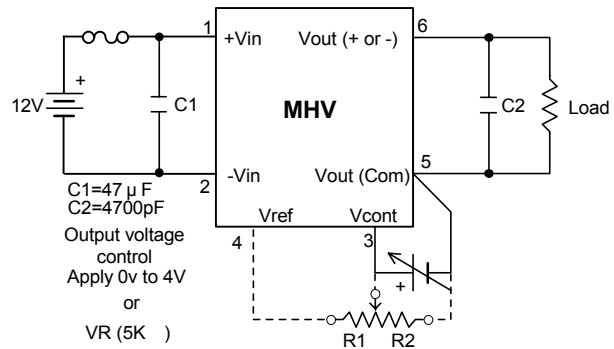

Output voltage - VR resistance value characteristic

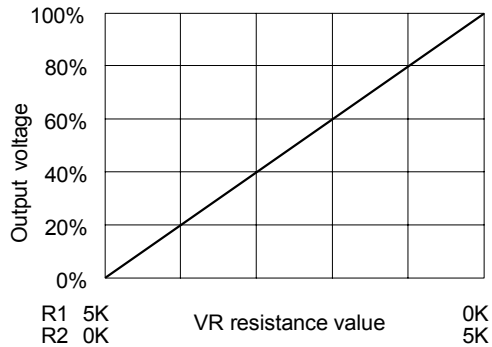

Output voltage - Output control voltage characteristic

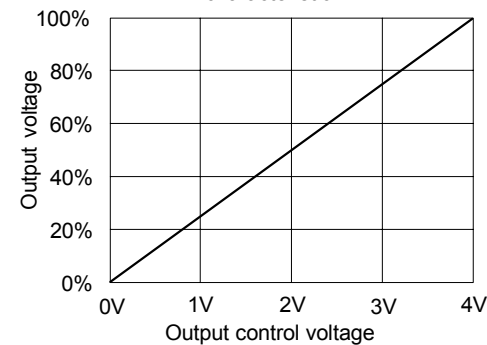

The above characteristics (Output voltage -VR resistance value characteristic) graph is an indication of the resistance value R1 and R2. When setting the voltage to a set rate using a stable resistor, first decide the adjustable resistor R1 and R2.

Do not apply voltage higher than 4V+5% on the Vcont. Choose an adjustable resistor appliance with good temp characteristics. When the resistance value for the adjustable resistor is 5.0K $\Omega$ , the max output voltage of 6.0V which is 100%, should be applied to Vcont pin. Since the max output voltage largely affects the margin of error for the resistance value, set the resistance value at 5.0K $\Omega$  $\pm$ 5%.

### Temp derating

When using the product where the ambient temp is higher than 50°C, follow the derating graph below, increasing the load resistance as the temp increases. The minimum load resistance value is specified for each series.

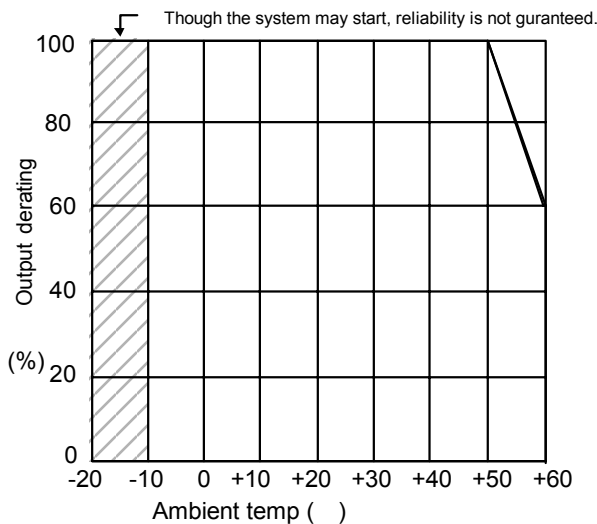

### Preventing reverse connections

The converter may break if the polarities are reversed. If there is a possibility in which the connections maybe reversed, connect a diode and fuse like below.

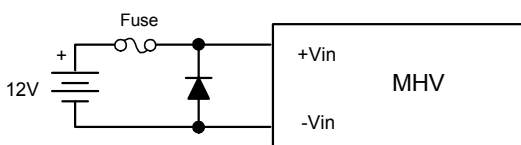

### Recommended solder conditions

Soldering conditions for each part are as follows:

- Using a soldering iron      340 to 360°C      5 sec.
- Using a soldering tub        230 to 260°C      10 sec.

### Decreasing the output noise further

The MHV series does need any external parts, however to lower the output noise farther, connect a capacitor C2 like the figure below.

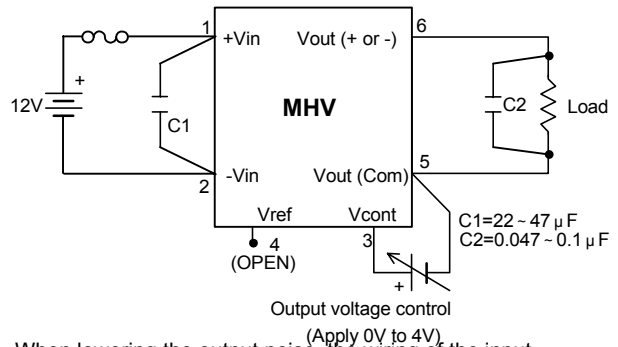

When lowering the output noise, the wiring of the input and output should be as short as possible. Place C2 closest to the load, paying attention to creepage and clearance distances.

### Point!

Choose a capacitor with a high-frequency when adding to the input.

Earth (COMMON) line should be thick and short in the pattern design to lower the common impedance.

The capacitor which is connected to the output side should be able to withstand the pressure, when connected to the loadside. At this time, the capacitor lead should be shortened. Also when the load response time is a problem, please be aware of the time constant.

### Safety standards

The MHV series has been certified with the UL / c-UL.

- UL60950-1 1st Ed.
- c-UL(CSA22.2 No.60950-1-03 1st Ed.)

When using this product as a recognized (certified) product, an input fuse should be mounted like below.

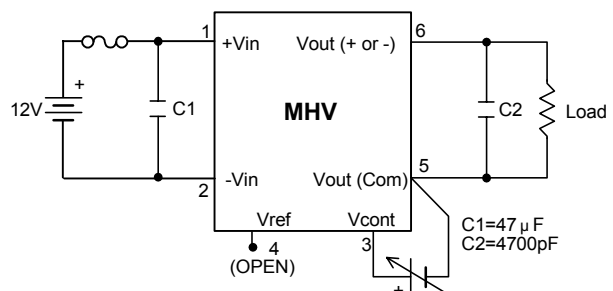

Choose a fuse from below:

- UL Listed products
- DC250V, Rated current 2A type

# Ultra small size adjustable output type high voltage power supply 2W to 2.6W high voltage DC-DC converter Bellnix® 0V-470V, 1000V, 1500V, 2000V MHV Series

The MHV series is the first high voltage product supply in the industry to use the latest SMT (surface mount technology) making the size 1/5 to 1/6 from the normal product, with an adjustable output voltage type mid-high voltage DC-DC converter. Output voltage can be controlled using an external voltage or external adjustable resistor. The MHV series has adopted a 5 side metallic shield, with farther low ripple and low noise.

## ■ Features

- PCB mounting type
- Output capacity 2W to 2.6W
- Over current protection
- Worlds smallest size device
- Low price
- UL certified product (UL File No. E305960)
- Adopted a 5 sided metallic shield case
- Remote ON/OFF control
- High reliability, long life
- Low ripple noise of 30mVp-p
- Adjustable voltage using an external voltage

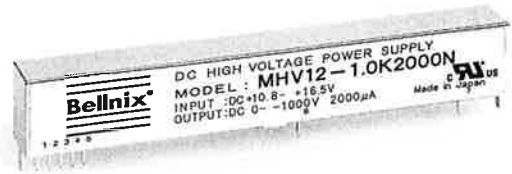

## ■ Model name/Rating

Model name MHV series	Input voltage (Vdc)	Output voltage (Vdc) Note1	Output current (mA)	Load resistance (KΩ) min	Output capacity (W)	Input current (mA) typ	Ripple noise (mVp-p) typ	Case
MHV12-470S06P	10.8 to 13.2	0 to +470	0 to 5.6	83.3	2.6	390	40	M-11
MHV12-470S06N	10.8 to 13.2	0 to -470	0 to 5.6	83.3	2.6	390	40	M-11
MHV12-1.0K2000P	10.8 to 6.5	0 to +1000	0 to 2	500	2.0	290	30	M-11
MHV12-1.0K2000N	10.8 to 16.5	0 to -1000	0 to 2	500	2.0	290	30	M-11
MHV12-1.5K1300P	10.8 to 16.5	0 to +1500	0 to 1.3	1150	2.0	290	30	M-11
MHV12-1.5K1300N	10.8 to 16.5	0 to -1500	0 to 1.3	1150	2.0	290	30	M-11
MHV12-2.0K1000P	10.8 to 16.5	0 to +2000	0 to 1	2000	2.0	340	50	M-11
MHV12-2.0K1000N	10.8 to 16.5	0 to -2000	0 to 1	2000	2.0	340	50	M-11

## ■ Specifications

Input regulation	0.03% typ.(Regulation of input voltage range)
Load regulation	470V type : 0.08%typ, 1KV, 1.5KV, 2KV type : 0.03% typ(Load current 0 to 100%)
Temp regulation	±0.01%/°C typ.(Temp. regulation (-10°C to +50°C))
Over current protection	Hold back characteristic, auto restart circuit operates at 105% or more.
Output voltage accuracy	Below ±5%(Rated output, rated load, 470V type is Vcont=3.76V, 1KV, 1.5KV, 2KV type is Vcont=4V)
Output voltage control	External voltage is 0V to +4V, or an adjustable resistor with 5KΩ.
ON/OFF control	Available (Between 2pin-5pin :when open=ON, when short=OFF)
Usage temperature range	-10°C to +60°C(Derating required for temp.50°C or higher )
Storage temperature range	-25°C to +85°C
Usage humidity range	20% to 95%RH(Non condensing)
Input/output isolation	Non isolated type (2pin-6pin and case are internally connected .)
MTBF expected value	390,000 to 400,000H min.(From the Bellnix MTBF formula graph)

Note1: The output voltage can be controlled by impressing the Vcont voltage. Using an adjustable resistor or an external voltage, voltage should be impressed on the Vcont pin in order to control the output voltage. When Vcont voltage=0V the output voltage(residual output voltage) should be less than 0.5% of the max output voltage (at Input/Output rating).

## ■ Test circuit

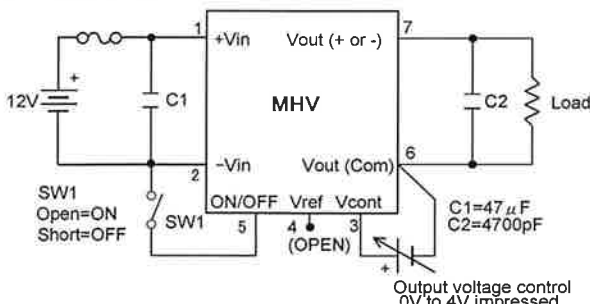

## ■ Block diagram

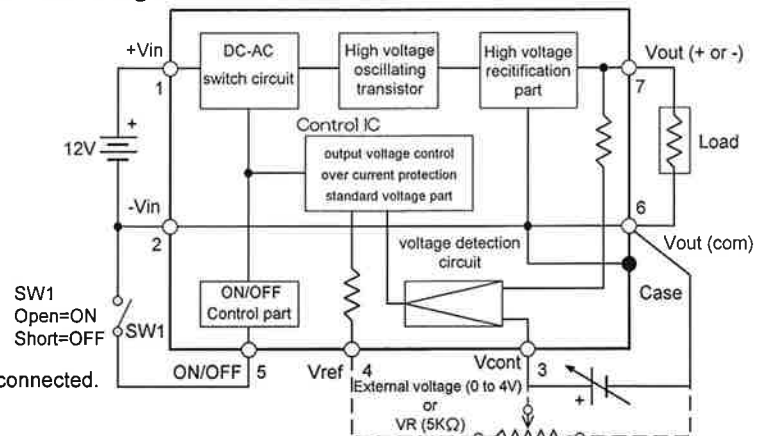

Warning 1: The input-output ground line and case are internally connected.

Warning 2: Vref is 4V (When external VR=5KΩ)

Warning 3: The ON/OFF can be controlled with a transistor.



## Over current protection

The MHV series installed the over current protection to protect from the over load and load short. When the product status is in over load or load short mode, the output voltage will be decreased, and once the problem has been removed, the voltage will automatically recover.

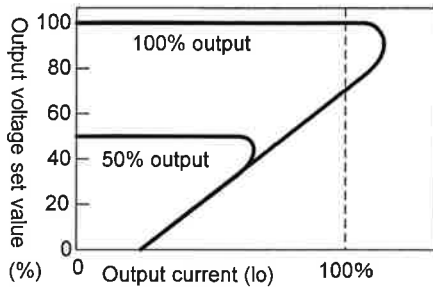

MHV Series  
Over current protection  
characteristic

The over current protection has a hold back characteristic. The load should be set more than minimum resistor value which according to each series.

## Recommended pattern

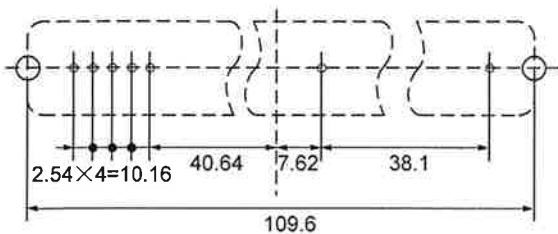

7—○ Diameter :  $\phi 1.2$       2—○ Diameter :  $\phi 2.5$

1)The MHV series uses a metallic case. When mounting to a double-sided PCB, the wiring for the converter should be on the soldering side.

Also, this converter will generate high voltages so the creepage distance of pattern should be taken in when designing.

2)When mounting to a double-sided PCB, the land of the parts side of the high voltage output pin should be as small as possible.

3)The case of MHV series should be connected to the -Vin and Vout (Com).

4)The metallic case does not need to be connecting to ground.

However, when using and ground with the metallic case, make the impedance lower as possible between the ground.

## Output voltage setting/adjusting

The output voltage on the MHV series can be set and adjusted using an external voltage or external adjustable resistor.

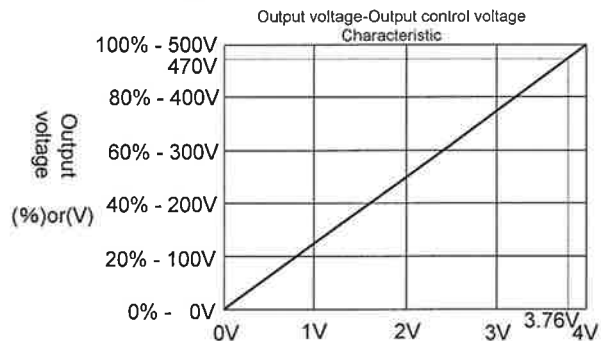
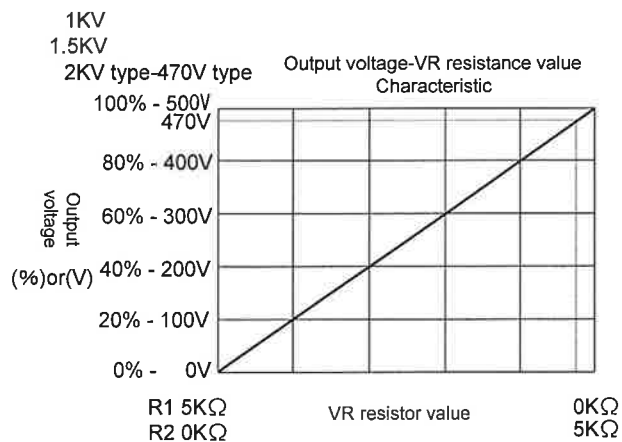
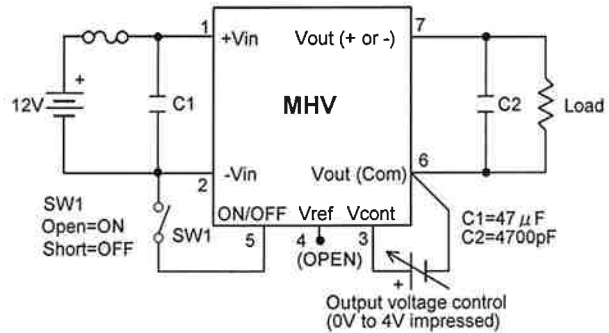

- The above characteristics (Output voltage -VR resistor value characteristic) graph is an indication of the resistance value R1 and R2. Please check the output voltage by the adjustable resistor etc. and adjust at the actual using.
- Do not impress voltage higher than 4V+5% on the Vcont.
- Choose an adjustable resistor appliance with good temperature characteristics.
- When the resistance value is 5.0KΩ(R1=0Ω, R2=5KΩ), the max.voltage 4.0V will impress to Vcont pin. Therefore, the margin of error for the resistance value will largely affect the max output voltage, so use the resistance value as 5.0KΩ±5%.

## ■ Vref pin (standard voltage output)

When adjusting the output voltage with an adjustable resistor, this pin is used. Vref has a standard output voltage of 4V. In this case, use an external resistor with a resistance of 5KΩ.

The resistance(the margin of error) of external adjustable resistor will affect the setting value of Vref pin voltage, so use a resistor with an accuracy of 5KΩ±5%.

The type of adjustable resistor will not matter, however one with a well temperature coefficient is recommended.

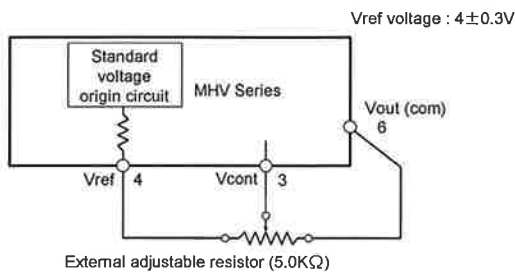

## ■ Temperature derating

When using the product where the ambient temp. is higher than 50°C, follow the derating graph below.

The minimum load resistance is set for each series.

When using higher than 50°C, set the load resistance high by following the below graph.

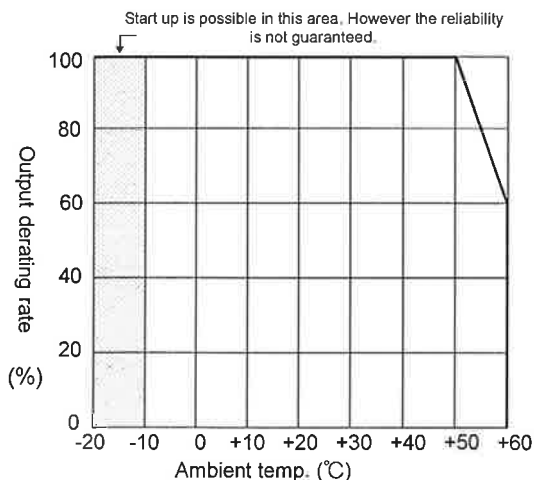

## ■ Prevention of inverse input connections

The converter may break if the polarities are reversed. If there is a possibility in which the connections maybe reversed, connect a diode and fuse to the input pin like below.

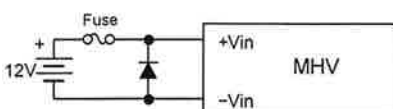

## ■ Recommended soldering conditions

Soldering conditions for each part is as follows:

- 1)Using a soldering iron 340 to 360°C 5 sec.
- 2)Using a soldering tub 230 to 260°C 10 sec.

## ■ Lowering the output noise even farther

The MHV series does need any external parts, however to lower the output noise even farther, connect a capacitor C2 like the figure below.

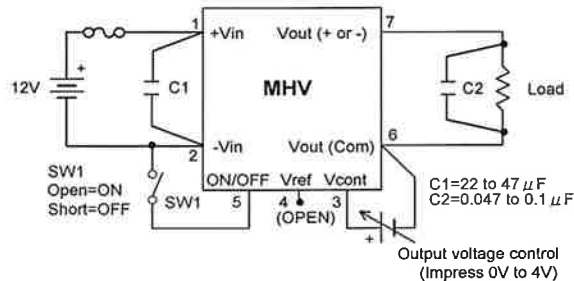

When lowering the output noise even more, keep in mind the input/output wiring, creepage and area distance, while keeping the wiring as thin as possible and layout the C2 near the Load.

### Point!

- 1) When choosing a capacitor that connect to the input, choose one which is a high frequency characteristic capacitor.
- 2) Common line should be designed thick and short to make same impedance small.
- 3) The capacitor which is connected to the output side should be able to withstand the pressure, and connect to the load side. At this time, the capacitor lead should be shortened. Also, when the load response time is a problem, please be aware of the time constant.

## ■ Safety standard

The MHV series has attained the UL/c-UL certification

- UL60950-1 1st Ed.
- c-UL(CSA22.2 No.60950-1-03 1st Ed.)

When using the MHV series as a Recognized certified product please mount an input fuse as shown below.

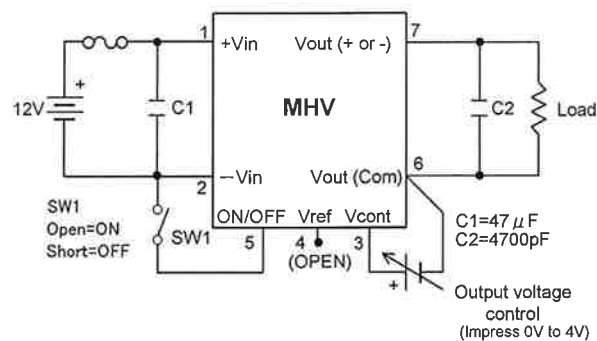

Choose a fuse from below:

- UL Listed products
- DC250V, Rated current 2A type

## ■ Guarantee

This product shall be guaranteed for year. During this period, if there should be any failure definitely due to our designing or manufacturing, we will repair or replace it with a new one at our expense. However, in any case that the product is modified and/or has made any interal remodlling by the buyer, the product can no longer be guaranteed. This guarantee shall cover only the MHV series.

■ If you have any further technical questions for this product, please contact to us.

E-mail: [info@bellnix.com](mailto:info@bellnix.com)

<http://www.bellnix.com>