

PennEngineering®

**FASTENERS FOR  
USE WITH PC BOARDS**



**BULLETIN**

**K**



**813  
REV. 715**











# FASTENERS FOR USE WITH PC BOARDS

No matter how sophisticated or advanced, electronic components must be attached reliably and securely if they are to deliver optimum performance. We offer several fastener products for use with PC boards to satisfy component-to-board, board-to-board, and board-to-chassis attachment needs.

**ReelFast® surface mount fasteners** mount on PC boards in the same manner and at the same time as other surface mount components prior to the automated reflow solder process. The fasteners simply become another board component. This alleviates concerns about potential damage to PC boards due to improper secondary installation operations. The fasteners are provided on tape and reel compatible with existing SMT automated installation equipment. The benefits of using ReelFast® SMT fasteners are: faster assembly; reduced scrap; reduced handling; and reduced risk of board damage.

**Broaching fasteners** can also offer practical alternatives to “loose” hardware. A broaching fastener is a knurled-shank fastening device that can be pressed into a hole to provide a permanent, strong, threaded or unthreaded attachment point in PC boards. They can also be used in aluminum, acrylic, casting and polycarbonate components. Specially formed axial grooves around the shank of the fastener “broach” or cut into the material, creating a firm, interference-type fit resistant to rotation. In PC boards, broaching fasteners are recommended for use in non-plated holes.

**Broach/flare-mount standoffs** (Type KFB3) offer a combined broach/flare feature for even greater pullout performance in PC board materials.

|  |  |
|--|--|
| <p><b>NUTS AND SPACERS/STANDOFFS</b></p> <p><b>Type SMTSO/SMTSOB</b> - ReelFast® surface mount nuts and standoffs are available threaded and unthreaded - <b>PAGE 4</b></p>  | <p><b>STUDS</b></p> <p><b>Type KFH</b> - Threaded broaching studs for use as solderable connectors or as permanently mounted studs on PC boards - <b>PAGE 10</b></p>                       |
| <p><b>Types KF2/KFS2</b> - Broaching nuts, internally threaded for mounting on PC boards - <b>PAGE 5</b></p>    | <p><b>RIGHT ANGLE FASTENERS</b></p> <p><b>Type SMTRA</b> - ReelFast® R'ANGLE® surface mount fasteners provide strong re-usable threads at right angles to PC boards - <b>PAGE 11</b></p>  |
| <p><b>Types KFE/KFSE</b> - Broaching standoffs, threaded or unthreaded for stacking or spacing - <b>PAGE 6</b></p>    | <p><b>SHEET JOINING FASTENERS</b></p> <p><b>Type SFK</b> - SpotFast® clinch/broach mount fasteners for joining metal to PCB/plastic panels - <b>PAGE 12</b></p>                           |
| <p><b>Type KFB3</b> - Broach/flare-mount standoffs with greater pullout performance - <b>PAGE 6</b></p>   | <p><b>MATERIAL AND FINISH SPECIFICATIONS -</b><br/><b>PAGE 13</b></p>  |
| <p><b>Type KSSB</b> - Broaching, SNAP-TOP® standoffs feature a spring action to hold PC board securely without screws or threaded hardware - <b>PAGE 7</b></p>              | <p><b>INSTALLATION -</b><br/><b>PAGES 14-15</b></p>  |
| <p><b>CAPTIVE PANEL SCREWS</b></p> <p><b>Type PSHP</b> - ReelFast® surface mount captive panel screws - <b>PAGE 8</b></p>   | <p><b>PERFORMANCE DATA -</b><br/><b>PAGES 16-17</b></p>  |
| <p><b>Type PFK</b> - Broaching panel fastener assemblies for mounting on PC boards - <b>PAGE 9</b></p>    | <p><b>OTHER FASTENERS FOR USE WITH PC BOARDS -</b><br/><b>PAGE 18</b></p>  |

# FASTENERS FOR USE WITH PC BOARDS

## NOTE ABOUT PLATED THRU-HOLES

Broaching and broach/flare types are designed for unplated thru-hole applications. If used in plated thru-hole applications, the stresses involved can damage the plating, push out the plating entirely, or break any traces inside the board that might be connected to the plated hole. Increasing the mounting hole size +.005" to +.008" / +0.13 to +0.2 may relieve these conditions. In non-plated thru-holes this will also help when delamination, measeling or crazing is evident after installation. When none of the above can be tolerated, we recommend Type SMTSO/SMTSOB (surface-mount) type fasteners.

General recommendations for "Keep Out" areas are the same as our "Min. Distance Hole C/L to Edge" dimensions stated in the dimensional charts of our bulletin.

## QUICK REFERENCE CHART

| PEM Fastener Type                   | Page No. | Mounting Types |              |               |               | Primary Use |                 |                 |      |               |              |                        |               |
|-------------------------------------|----------|----------------|--------------|---------------|---------------|-------------|-----------------|-----------------|------|---------------|--------------|------------------------|---------------|
|                                     |          | Broach         | Broach/Flare | Surface Mount | Clinch/Broach | Nut         | Spacer/Standoff | Snap Attachment | Stud | Captive Screw | Color Coding | Right Angle Attachment | Sheet Joining |
| SMTSO/SMTSOB<br>Nut/Spacer/Standoff | 4        |                |              | •             |               | •           | •               |                 |      |               |              |                        |               |
| KF2/KFS2<br>Nut                     | 5        | •              |              |               |               | •           |                 |                 |      |               |              |                        |               |
| KFE/KFSE<br>Spacer/Standoff         | 6        | •              |              |               |               |             | •               |                 |      |               |              |                        |               |
| KFB3<br>Standoff                    | 6        |                | •            |               |               |             | •               |                 |      |               |              |                        |               |
| KSSB<br>Standoff                    | 7        | •              |              |               |               |             | •               | •               |      |               |              |                        |               |
| SMTPF<br>Assembly                   | 8        |                |              | •             |               |             |                 |                 |      | •             | •            |                        |               |
| PFK<br>Captive Screw                | 9        | •              |              |               |               |             |                 |                 |      | •             |              |                        |               |
| KFH<br>Stud                         | 10       | •              |              |               |               |             |                 |                 | •    |               |              |                        |               |
| SMTRA<br>Right Angle                | 11       |                |              | •             |               |             |                 |                 |      |               |              | •                      |               |
| SFK<br>Sheet Joining                | 12       | •              |              |               | •             |             |                 |                 |      |               |              |                        | •             |

# FASTENERS FOR USE WITH PC BOARDS

## TYPES SMTSO/SMTSOB ReelFast® SURFACE MOUNT NUTS AND SPACERS/STANDOFFS

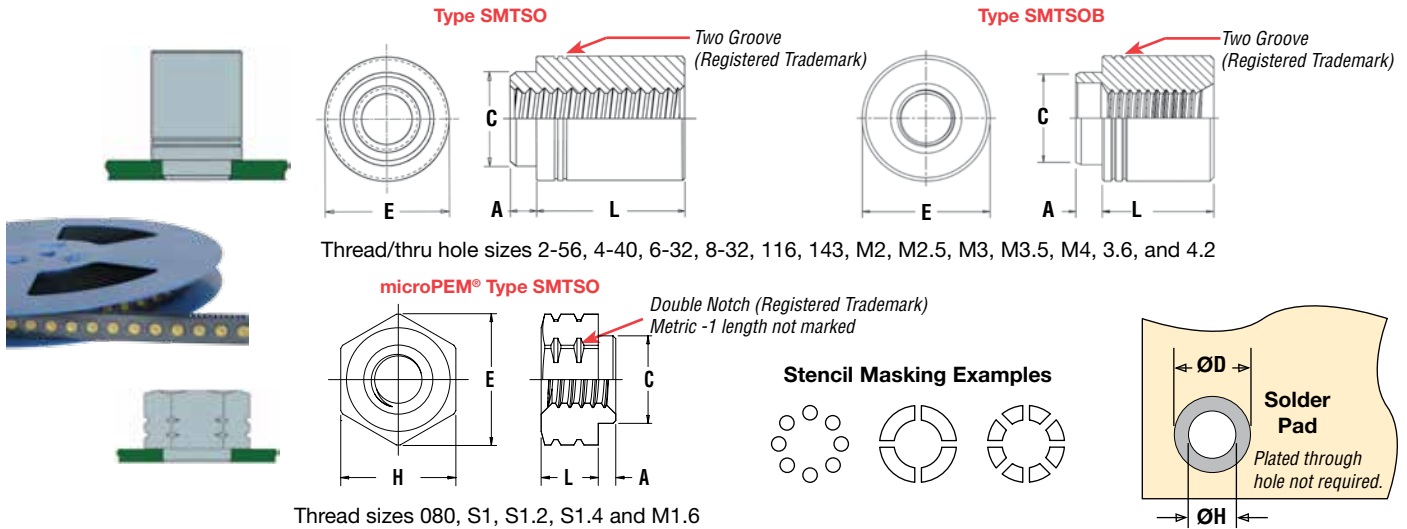

All dimensions are in inches.

| UNIFIED | Thread Size     | Thru Hole<br>+.004 -.003 | Type              |        | Thread or Thru Hole Code | Length Code "L" ±.005<br>(Length code in 32nds of an inch) |      |                  |                   | Min. Sheet Thickness | A Max. | C Max. | E    |      | H Nom. | ØH Hole Size<br>In Sheet<br>+.003 -.000 | ØD Min. Solder Pad |       |
|---------|-----------------|--------------------------|-------------------|--------|--------------------------|--|------|------------------|-------------------|----------------------|--------|--------|------|------|--------|---|--------------------|-------|
|         |                 |                          | Fastener Material | Steel  |                          | Brass  | .062 | .125             | .250              |                      |        |        | .375 | Ref. |        |   |                    | ±.005 |
|         |                 |                          |                   |        |                          |  |      |                  |                   |                      |        |        |      |      |        |   |                    |       |
|         | .060-80 (#0-80) | —                        | SMTSO             | —      | 080                      | 2  | 4    | —                | —                 | .020                 | .019   | .095   | .144 | —    | .125   | .098                                    | .165               |       |
|         | .086-56 (#2-56) | —                        | SMTSO             | SMTSOB | 256                      | 2  | 4    | 8 <sup>(1)</sup> | 12 <sup>(1)</sup> | .060                 | .060   | .142   | —    | .219 | —      | .147                                    | .244               |       |
|         | .112-40 (#4-40) | —                        | SMTSO             | SMTSOB | 440                      | 2  | 4    | 8 <sup>(1)</sup> | 12 <sup>(1)</sup> | .060                 | .060   | .161   | —    | .219 | —      | .166                                    | .244               |       |
|         | .138-32 (#6-32) | —                        | SMTSO             | SMTSOB | 632                      | 2  | 4    | 8 <sup>(1)</sup> | 12 <sup>(1)</sup> | .060                 | .060   | .208   | —    | .281 | —      | .213                                    | .306               |       |
|         | .164-32 (#8-32) | —                        | SMTSO             | SMTSOB | 832                      | 2  | 4    | 8 <sup>(1)</sup> | 12 <sup>(1)</sup> | .060                 | .060   | .245   | —    | .344 | —      | .250                                    | .369               |       |
|         | —               | .116                     | SMTSO             | SMTSOB | 116                      | 2  | 4    | 8                | 12                | .060                 | .060   | .161   | —    | .219 | —      | .166                                    | .244               |       |
|         | —               | .143                     | SMTSO             | SMTSOB | 143                      | 2  | 4    | 8                | 12                | .060                 | .060   | .208   | —    | .281 | —      | .213                                    | .306               |       |

All dimensions are in millimeters.

| METRIC | Thread Size x Pitch | Thru Hole<br>+.010<br>-0.08 | Type              |        | Thread or Thru Hole Code | Length Code "L" ±0.13<br>(Length code in millimeters) |   |   |                  |                  |                  | Min. Sheet Thickness | A Max. | C Max. | E    |      | H Nom. | ØH Hole Size<br>In Sheet<br>+0.08 | ØD Min. Solder Pad |      |       |
|--------|---------------------|-----------------------------|-------------------|--------|--------------------------|---|---|---|------------------|------------------|------------------|----------------------|--------|--------|------|------|--------|-----------------------------------|--------------------|------|-------|
|        |                     |                             | Fastener Material | Steel  |                          | Brass   | 1 | 2 | 3                | NA               | NA               |                      |        |        | NA   | —    |        |                                   |                    | Ref. | ±0.13 |
|        |                     |                             |                   |        |                          |   |   |   |                  |                  |                  |                      |        |        |      |      |        |                                   |                    |      |       |
|        | S1                  | —                           | SMTSO             | —      | M1                       | 1   | 2 | 3 | NA               | NA               | NA               | —                    | 0.5    | 0.48   | 2.41 | 3.66 | —      | 3.18                              | 2.5                | 4.19 |       |
|        | S1.2                | —                           | SMTSO             | —      | M1.2                     | 1   | 2 | 3 | NA               | NA               | NA               | —                    | 0.5    | 0.48   | 2.41 | 3.66 | —      | 3.18                              | 2.5                | 4.19 |       |
|        | S1.4                | —                           | SMTSO             | —      | M1.4                     | 1   | 2 | 3 | NA               | NA               | —                | —                    | 0.5    | 0.48   | 2.41 | 3.66 | —      | 3.18                              | 2.5                | 4.19 |       |
|        | M1.6 x 0.35         | —                           | SMTSO             | —      | M1.6                     | 1   | 2 | 3 | NA               | NA               | —                | —                    | 0.5    | 0.48   | 2.41 | 3.66 | —      | 3.18                              | 2.5                | 4.19 |       |
|        | M2 x 0.4            | —                           | SMTSO             | SMTSOB | M2                       | —   | 2 | 3 | 4 <sup>(1)</sup> | 6 <sup>(1)</sup> | 8 <sup>(1)</sup> | 10 <sup>(1)</sup>    | 1.53   | 1.53   | 3.6  | —    | 5.56   | —                                 | 3.73               | 6.2  |       |
|        | M2.5 x 0.45         | —                           | SMTSO             | SMTSOB | M25                      | —   | 2 | 3 | 4 <sup>(1)</sup> | 6 <sup>(1)</sup> | 8 <sup>(1)</sup> | 10 <sup>(1)</sup>    | 1.53   | 1.53   | 4.09 | —    | 5.56   | —                                 | 4.22               | 6.2  |       |
|        | M3 x 0.5            | —                           | SMTSO             | SMTSOB | M3                       | —   | 2 | 3 | 4 <sup>(1)</sup> | 6 <sup>(1)</sup> | 8 <sup>(1)</sup> | 10 <sup>(1)</sup>    | 1.53   | 1.53   | 4.09 | —    | 5.56   | —                                 | 4.22               | 6.2  |       |
|        | M3.5 x 0.6          | —                           | SMTSO             | SMTSOB | M35                      | —   | 2 | 3 | 4 <sup>(1)</sup> | 6 <sup>(1)</sup> | 8 <sup>(1)</sup> | 10 <sup>(1)</sup>    | 1.53   | 1.53   | 5.28 | —    | 7.14   | —                                 | 5.41               | 7.77 |       |
|        | M4 x 0.7            | —                           | SMTSO             | SMTSOB | M4                       | —   | 2 | 3 | 4                | 6 <sup>(1)</sup> | 8 <sup>(1)</sup> | 10 <sup>(1)</sup>    | 1.53   | 1.53   | 6.22 | —    | 8.74   | —                                 | 6.35               | 9.37 |       |
|        | —                   | 3.6                         | SMTSO             | SMTSOB | 3.6                      | —   | 2 | 3 | 4                | 6                | 8                | 10                   | 1.53   | 1.53   | 5.28 | —    | 7.14   | —                                 | 5.41               | 7.77 |       |
|        | —                   | 4.2                         | SMTSO             | SMTSOB | 4.2                      | —   | 2 | 3 | 4                | 6                | 8                | 10                   | 1.53   | 1.53   | 6.22 | —    | 8.74   | —                                 | 6.35               | 9.37 |       |

(1) Type SMTSOB Fasteners with this length code have a shank counterbore.

### NUMBER OF PARTS PER REEL / PITCH (MM) FOR EACH SIZE

| Thread/Thru-Hole Size   | Length Code |           |           |           |          |          |          |          |
|-------------------------|-------------|-----------|-----------|-----------|----------|----------|----------|----------|
|                         | 1           | 2         | 3         | 4         | 6        | 8        | 10       | 12       |
| 080                     | —           | 3500 / 8  | —         | 2000 / 8  | —        | —        | —        | —        |
| 256, 440, 632, 116, 143 | —           | 1500 / 12 | —         | 1000 / 12 | —        | 650 / 12 | —        | 300 / 16 |
| 832                     | —           | 1100 / 16 | —         | 800 / 16  | —        | 500 / 16 | —        | 300 / 16 |
| M1, M1.2, M1.4, M1.6    | 3500 / 8    | 2500 / 8  | 2000 / 8  | —         | —        | —        | —        | —        |
| M2, M25, M3, M35, 3.6   | —           | 1500 / 12 | 1000 / 12 | 900 / 12  | 650 / 12 | 375 / 16 | 300 / 16 | —        |
| M4, 4.2                 | —           | 1100 / 16 | 800 / 16  | 675 / 16  | 500 / 16 | 375 / 16 | 300 / 16 | —        |

### PART NUMBER DESIGNATION

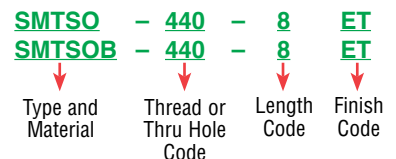

Packaged on 330 mm recyclable reels. Tape width is 24 mm. Supplied with polyimide patch for vacuum pick up. Reels conform to EIA-481.



# FASTENERS FOR USE WITH PC BOARDS

## TYPES KF2 AND KFS2 BROACHING NUTS

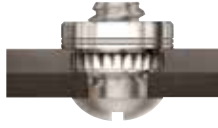

### PART NUMBER DESIGNATION

**KFS2 - 832**  
**KF2 - 832 - ET**

↓                      ↓                      ↓  
 Type and              Thread              Finish  
 Material              Code              Code  
 KF2 = carbon steel  
 KFS2 = stainless steel

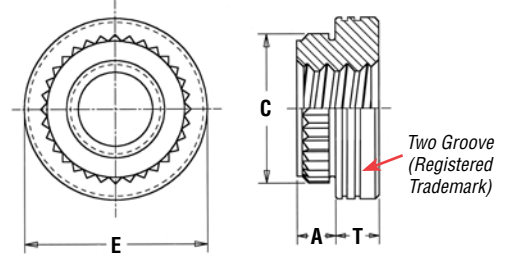

All dimensions are in inches.

| UNIFIED | Thread Size      | Type         |                 | Thread Code | A (Shank) Max. | Min. Sheet Thickness | Hole Size In Sheet +.003 - .000 | C ±.003 | E ±.005 | T ±.005 | Min. Dist. Hole $\phi$ To Edge |
|---------|------------------|--------------|-----------------|-------------|----------------|----------------------|---------------------------------|---------|---------|---------|--------------------------------|
|         |                  | Carbon Steel | Stainless Steel |             |                |                      |                                 |         |         |         |                                |
|         | .086-56 (#2-56)  | KF2          | KFS2            | 256         | .060           | .060                 | .147                            | .165    | .219    | .065    | 0.16                           |
|         | .112-40 (#4-40)  | KF2          | KFS2            | 440         | .060           | .060                 | .166                            | .184    | .219    | .065    | 0.17                           |
|         | .138-32 (#6-32)  | KF2          | KFS2            | 632         | .060           | .060                 | .213                            | .231    | .281    | .065    | 0.22                           |
|         | .164-32 (#8-32)  | KF2          | KFS2            | 832         | .060           | .060                 | .250                            | .268    | .344    | .096    | 0.25                           |
|         | .190-32 (#10-32) | KF2          | KFS2            | 032         | .060           | .060                 | .272                            | .290    | .375    | .127    | 0.28                           |

All dimensions are in millimeters.

| METRIC | Thread Size x Pitch | Type         |                 | Thread Code | A (Shank) Max. | Min. Sheet Thickness | Hole Size In Sheet +0.08 | C ±0.08 | E ±0.13 | T ±0.13 | Min. Dist. Hole $\phi$ To Edge |
|--------|---------------------|--------------|-----------------|-------------|----------------|----------------------|--------------------------|---------|---------|---------|--------------------------------|
|        |                     | Carbon Steel | Stainless Steel |             |                |                      |                          |         |         |         |                                |
|        | M2 x 0.4            | KF2          | KFS2            | M2          | 1.53           | 1.53                 | 3.73                     | 4.19    | 5.56    | 1.5     | 4.2                            |
|        | M2.5 x 0.45         | KF2          | KFS2            | M2.5        | 1.53           | 1.53                 | 4.22                     | 4.68    | 5.56    | 1.5     | 4.4                            |
|        | M3 x 0.5            | KF2          | KFS2            | M3          | 1.53           | 1.53                 | 4.22                     | 4.68    | 5.56    | 1.5     | 4.4                            |
|        | M4 x 0.7            | KF2          | KFS2            | M4          | 1.53           | 1.53                 | 6.4                      | 6.81    | 8.74    | 2       | 6.4                            |
|        | M5 x 0.8            | KF2          | KFS2            | M5          | 1.53           | 1.53                 | 6.9                      | 7.37    | 9.53    | 3       | 7.1                            |



# FASTENERS FOR USE WITH PC BOARDS

## TYPES KFE AND KFSE BROACHING STANDOFFS



### PART NUMBER DESIGNATION

**KFSE** - **632** - **12**  
**KFE** - **632** - **12** **ET**

↓ Type and Material    ↓ Thread or Thru Hole Code    ↓ Length Code    ↓ Finish Code  
 KFE = carbon steel  
 KFSE = stainless steel

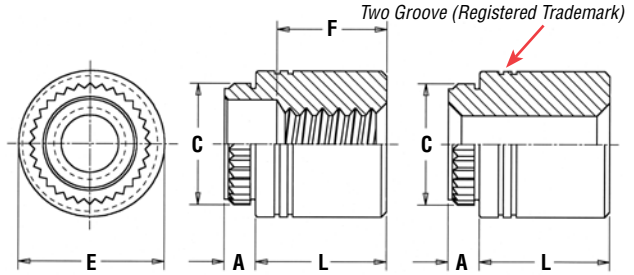

All dimensions are in inches.

| UNIFIED                                      | Thread Size     | Thru Hole<br>+.004<br>-.003 | Type         |                 | Thread or Thru Hole Code | Length "L" ±.005<br>(Length Code is in 32nds of an inch) |      |      |            |      |             |             |             | A (Shank) Max. | Min. Sheet Thickness | Hole Size In Sheet<br>+.003 - .000 | C ±.003 | E ±.005 | Min. Dist. Hole $\phi$ To Edge |
|--|-----------------|-----------------------------|--------------|-----------------|--------------------------|--|------|------|------------|------|-------------|-------------|-------------|----------------|----------------------|------------------------------------|---------|---------|--------------------------------|
|  |                 |                             | Carbon Steel | Stainless Steel |                          | .125   | .250 | .375 | .500       | .625 | (1)<br>.750 | (1)<br>.875 | (1)<br>1.00 |                |                      |                                    |         |         |                                |
|  | .112-40 (#4-40) | —                           | KFE          | KFSE            | 440                      | 4  | 8    | 12   | 16         | 20   | 24          | —           | —           | .060           | .060                 | .166                               | .184    | .219    | .17                            |
|  | .138-32 (#6-32) | —                           | KFE          | KFSE            | 632                      | 4  | 8    | 12   | 16         | 20   | 24          | 28          | 32          | .060           | .060                 | .213                               | .231    | .281    | .22                            |
|  | —               | .116                        | KFE          | KFSE            | 116                      | 4  | 8    | 12   | 16         | 20   | 24          | —           | —           | .060           | .060                 | .166                               | .184    | .219    | .17                            |
|  | —               | .143                        | KFE          | KFSE            | 143                      | 4  | 8    | 12   | 16         | 20   | 24          | 28          | 32          | .060           | .060                 | .213                               | .231    | .281    | .22                            |
| "F" Minimum Thread Length (Where Applicable) |                 |                             |              |                 |                          | Full   |      |      | .375 ±.016 |      |             | .375 Blind  |             |                |                      |                                    |         |         |                                |

All dimensions are in millimeters.

| METRIC                                       | Thread Size x Pitch | Thru Hole<br>+0.10<br>-0.08 | Type         |                 | Thread or Thru Hole Code | Length "L" ±0.13<br>(Length Code is in millimeters) |   |   |           |    |    |    |    | A (Shank) Max. | Min. Sheet Thickness | Hole Size In Sheet<br>+0.08 | C ±0.08 | E ±0.13 | Min. Dist. Hole $\phi$ To Edge |
|--|---------------------|-----------------------------|--------------|-----------------|--------------------------|---|---|---|-----------|----|----|----|----|----------------|----------------------|-----------------------------|---------|---------|--------------------------------|
|  |                     |                             | Carbon Steel | Stainless Steel |                          | 3   | 4 | 6 | 8         | 10 | 12 | 14 | 16 |                |                      |                             |         |         |                                |
|  | M3 x 0.5            | —                           | KFE          | KFSE            | M3                       | 3   | 4 | 6 | 8         | 10 | 12 | 14 | 16 | 1.53           | 1.53                 | 4.22                        | 4.68    | 5.56    | 4.4                            |
|  | —                   | 3.6                         | KFE          | KFSE            | 3.6                      | 3   | 4 | 6 | 8         | 10 | 12 | 14 | 16 | 1.53           | 1.53                 | 5.41                        | 5.87    | 7.14    | 5.5                            |
|  | —                   | 4.2                         | KFE          | KFSE            | 4.2                      | 3   | 4 | 6 | 8         | 10 | 12 | 14 | 16 | 1.53           | 1.53                 | 6.4                         | 6.86    | 8.74    | 7.1                            |
| "F" Minimum Thread Length (Where Applicable) |                     |                             |              |                 |                          | Full  |   |   | 9.5 ± 0.4 |    |    |    |    |                |                      |                             |         |         |                                |

## TYPE KFB3 BROACH/FLARE-MOUNT STANDOFFS



### PART NUMBER DESIGNATION

**KFB3** - **632** - **12** **ET**

↓ Type and Material    ↓ Thread Code    ↓ Length Code    ↓ Finish Code

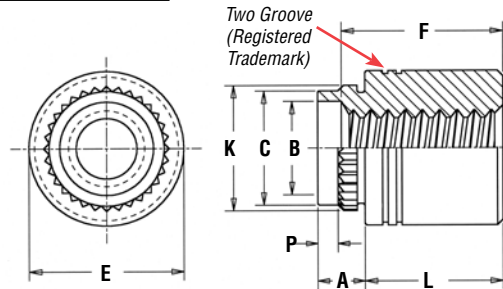

All dimensions are in inches.

| UNIFIED                                   | Thread Size     | Type | Thread Code | Length "L" ±.005<br>(Length Code is in 32nds of an inch) |      |      |      |      |      |      |      |             |             | A (Shank) Max. | Sheet Thickness | Hole Size in Sheet<br>+.005<br>-.001 | B ±.003 | C Max. | E ±.005 | K ±.003 | P ±.010 | Min. Dist. Hole $\phi$ To Edge |
|---|-----------------|------|-------------|--|------|------|------|------|------|------|------|-------------|-------------|----------------|-----------------|--------------------------------------|---------|--------|---------|---------|---------|--------------------------------|
|   |                 |      |             | .062   | .125 | .187 | .250 | .312 | .375 | .500 | .625 | (1)<br>.750 | (1)<br>1.00 |                |                 |                                      |         |        |         |         |         |                                |
|   | .112-40 (#4-40) | KFB3 | 440         | 2  | 4    | 6    | 8    | 10   | 12   | 16   | 20   | —           | —           | .09            | .050-.065       | .166                                 | .122    | .165   | .219    | .179    | .040    | .17                            |
|   | .138-32 (#6-32) | KFB3 | 632         | 2  | 4    | 6    | 8    | 10   | 12   | 16   | 20   | 24          | 32          | .09            | .050-.065       | .213                                 | .171    | .212   | .280    | .226    | .040    | .22                            |
| "F" Min. Thread Length (Where Applicable) |                 |      |             | Full   |      |      |      |      |      |      |      | .375 Blind  |             |                |                 |                                      |         |        |         |         |         |                                |

All dimensions are in millimeters.

| METRIC                                    | Thread Size x Pitch | Type | Thread Code | Length "L" ±0.13<br>(Length Code is in millimeters) |   |   |   |   |    |    |    | A (Shank) Max. | Sheet Thickness | Hole Size in Sheet<br>+0.13<br>-0.03 | B ±0.08 | C Max. | E ±0.13 | K ±0.08 | P ±0.25 | Min. Dist. Hole $\phi$ To Edge |      |
|---|---------------------|------|-------------|---|---|---|---|---|----|----|----|----------------|-----------------|--------------------------------------|---------|--------|---------|---------|---------|--------------------------------|------|
|   |                     |      |             | 2   | 3 | 4 | 6 | 8 | 10 | 12 | 14 |                |                 |                                      |         |        |         |         |         |                                | 16   |
|   | M3 x 0.5            | KFB3 | M3          | 2   | 3 | 4 | 6 | 8 | 10 | 12 | 14 | 16             | 2.29            | 1.27-1.65                            | 4.22    | 3.23   | 4.2     | 5.56    | 4.55    | 1                              | 4.33 |
|   | M4 x 0.7            | KFB3 | M4          | 2   | 3 | 4 | 6 | 8 | 10 | 12 | 14 | 16             | 2.29            | 1.27-1.65                            | 6.4     | 5.23   | 6.33    | 8.74    | 6.68    | 1                              | 6.36 |
| "F" Min. Thread Length (Where Applicable) |                     |      |             | Full  |   |   |   |   |    |    |    | 9.5 ± 0.4      |                 |                                      |         |        |         |         |         |                                |      |

(1) Blind at shank end with .375" minimum thread length from head end.





# FASTENERS FOR USE WITH PC BOARDS

## ReelFast® SURFACE MOUNT CAPTIVE PANEL SCREWS

Patented.

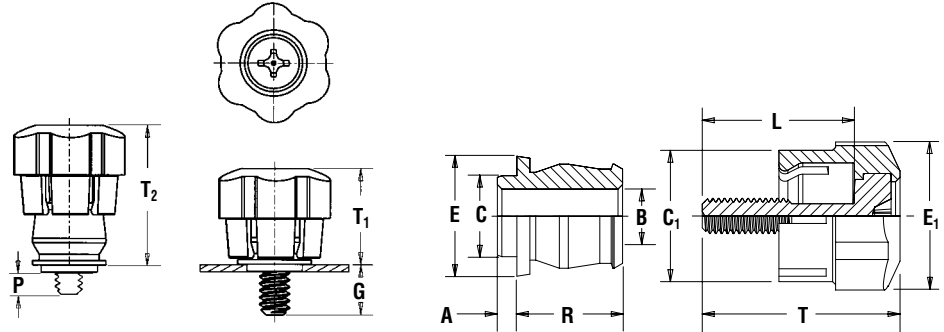
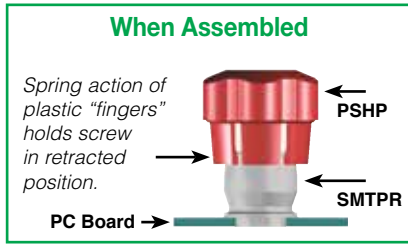

All dimensions are in inches.

| UNIFIED            | Screw Part Number  |      |             |                   | Assembly Dimensions  |              |              |                        |                        | Screw Dimensions   |                         |                         |              | Retainer Dimensions |                      |                   |            |           |           |            |
|--------------------|--------------------|------|-------------|-------------------|----------------------|--------------|--------------|------------------------|------------------------|--------------------|-------------------------|-------------------------|--------------|---------------------|----------------------|-------------------|------------|-----------|-----------|------------|
|                    | Thread Size        | Type | Thread Code | Screw Length Code | Retainer Part Number | G<br>±.025   | P<br>±.025   | T <sub>1</sub><br>Nom. | T <sub>2</sub><br>Nom. | Total Radial Float | C <sub>1</sub><br>±.010 | E <sub>1</sub><br>±.010 | L<br>±.015   | T<br>Nom.           | A<br>(Shank)<br>Max. | Min. Sheet Thick. | B<br>±.003 | C<br>Max. | E<br>Nom. | R<br>±.005 |
|                    | .112-40<br>(#4-40) | PSHP | 440         | 0<br>1            | SMTPR-6-1            | .188<br>.248 | .000<br>.026 | .478                   | .646                   | .015               | .440                    | .542                    | .510<br>.570 | .663<br>.723        | .060                 | .060              | .167       | .249      | .375      | .325       |
| .138-32<br>(#6-32) | PSHP               | 632  | 0<br>1      | SMTPR-6-1         | .188<br>.248         | .000<br>.026 | .478         | .646                   | .020                   | .440               | .542                    | .510<br>.570            | .663<br>.723 | .060                | .060                 | .167              | .249       | .375      | .325      |            |

All dimensions are in millimeters.

| METRIC     | Screw Part Number   |      |             |                   | Assembly Dimensions  |             |            |                        |                        | Screw Dimensions   |                         |                         |                | Retainer Dimensions |                      |                   |            |           |           |            |
|------------|---------------------|------|-------------|-------------------|----------------------|-------------|------------|------------------------|------------------------|--------------------|-------------------------|-------------------------|----------------|---------------------|----------------------|-------------------|------------|-----------|-----------|------------|
|            | Thread Size x Pitch | Type | Thread Code | Screw Length Code | Retainer Part Number | G<br>±0.64  | P<br>±0.64 | T <sub>1</sub><br>Nom. | T <sub>2</sub><br>Nom. | Total Radial Float | C <sub>1</sub><br>±0.25 | E <sub>1</sub><br>±0.25 | L<br>±0.38     | T<br>Nom.           | A<br>(Shank)<br>Max. | Min. Sheet Thick. | B<br>±0.08 | C<br>Max. | E<br>Nom. | R<br>±0.13 |
|            | M3 x 0.5            | PSHP | M3          | 0<br>1            | SMTPR-6-1            | 4.78<br>6.3 | 0<br>.66   | 12.14                  | 16.41                  | .38                | 11.18                   | 13.77                   | 12.95<br>14.48 | 16.84<br>18.36      | 1.53                 | 1.53              | 4.24       | 6.33      | 9.53      | 8.26       |
| M3.5 x 0.6 | PSHP                | M3.5 | 0<br>1      | SMTPR-6-1         | 4.78<br>6.3          | 0<br>.66    | 12.14      | 16.41                  | .51                    | 11.18              | 13.77                   | 12.95<br>14.48          | 16.84<br>18.36 | 1.53                | 1.53                 | 4.24              | 6.33       | 9.53      | 8.26      |            |

**RETAINER** - Packaged on 330 mm recyclable reels of 465 pieces. Tape width is 24 mm. Supplied with Kapton® patch for vacuum pick up. Reels conform to EIA-481.

**SCREW** - Packaged in bags. Retainers and screws are sold separately.

### PART NUMBER DESIGNATION FOR SCREW

**PSHP - 632 - 0 L 001**

Type Thread Code Length Code Cap Style Color Code  
(Lobed) (Standard Black)

### PART NUMBER DESIGNATION FOR RETAINER

**SMTPR - 6 - 1 ET**

Type Retainer Size Shank Code Finish Code

### COLOR CAPABILITIES FOR TYPE PSHP SCREW

The colors shown here (codes #002 thru #007) are non-stocked standards and available on special order. Since actual cap colors may vary slightly from those shown here, we recommend that you request samples for color verification. If you require a custom color or you need a "color matched" cap, please contact us.

Std. Black #001 Red #002 Orange #003 Yellow #004



Green #005 Blue #006 Violet #007

Non-flammable UL 94-V0 plastic caps are available on special order.

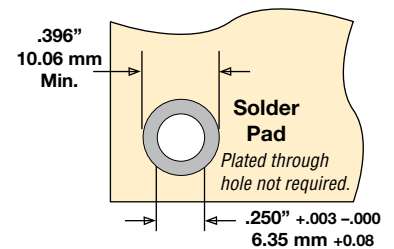
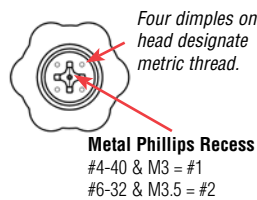

### Stencil Masking Examples



# FASTENERS FOR USE WITH PC BOARDS

## TYPE PFK BROACHING CAPTIVE PANEL SCREWS



### PART NUMBER DESIGNATION

**PFK** - **632** - **62**  
 ↓                      ↓                      ↓  
 Type                      Thread Size Code                      Screw Length Code

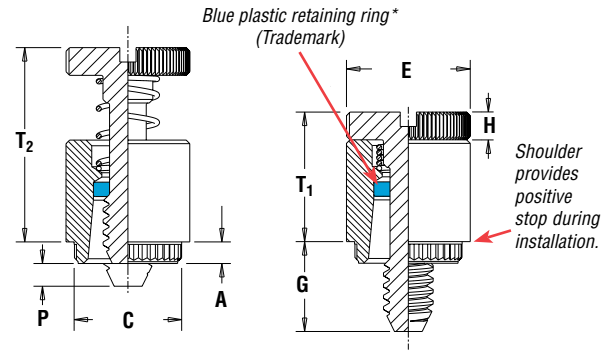
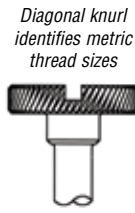

All dimensions are in inches.

| UNIFIED         | Thread Size     | Type | Thread Code | Screw Length Code | A (Shank) Max. | Min. Sheet Thickness | Hole Size In Sheet +.003 - .000 | C ±.003 | E ±.010 | G ±.016 | H ±.005 | P ±.025 (1) | T <sub>1</sub> Max. | T <sub>2</sub> Nom. | Min. Dist. Hole $\Phi$ To Edge |
|-----------------|-----------------|------|-------------|-------------------|----------------|----------------------|---------------------------------|---------|---------|---------|---------|-------------|---------------------|---------------------|--------------------------------|
|                 | .112-40 (#4-40) | PFK  | 440         | 40                | .060           | .060                 | .265                            | .283    | .312    | .072    | .250    | .000        | .36                 | .54                 | .20                            |
|                 |                 |      |             | 62                |                |                      |                                 |         |         |         | .125    |             |                     |                     |                                |
|                 |                 |      |             | 84                |                |                      |                                 |         |         |         | .250    |             |                     |                     |                                |
| .138-32 (#6-32) | PFK             | 632  | 40          | .060              | .060           | .281                 | .299                            | .344    | .072    | .250    | .000    | .36         | .54                 | .26                 |                                |
|                 |                 |      | 62          |                   |                |                      |                                 |         |         | .125    |         |             |                     |                     |                                |
|                 |                 |      | 84          |                   |                |                      |                                 |         |         | .250    |         |             |                     |                     |                                |

All dimensions are in millimeters.

| METRIC | Thread Size x Pitch | Type | Thread Code | Screw Length Code | A (Shank) Max. | Min. Sheet Thickness | Hole Size In Sheet +0.08 | C ±0.08 | E ±0.25 | G ±0.4 | H ±0.13 | P ±0.64 (1) | T <sub>1</sub> Max. | T <sub>2</sub> Nom. | Min. Dist. Hole $\Phi$ To Edge |
|--------|---------------------|------|-------------|-------------------|----------------|----------------------|--------------------------|---------|---------|--------|---------|-------------|---------------------|---------------------|--------------------------------|
|        | M3 x 0.5            | PFK  | M3          | 40                | 1.53           | 1.53                 | 6.73                     | 7.19    | 7.92    | 1.83   | 6.4     | 0           | 9.14                | 13.72               | 5.08                           |
|        |                     |      |             | 62                |                |                      |                          |         |         |        | 3.2     |             |                     |                     |                                |
|        |                     |      |             | 84                |                |                      |                          |         |         |        | 6.4     |             |                     |                     |                                |

\*Retaining rings are plastic with normal 250°F / 120°C temperature limit.  
 (1) Screw may protrude .005"/0.13 mm beyond nominal dimensions.

# FASTENERS FOR USE WITH PC BOARDS

## TYPE KFH BROACHING STUDS



### PART NUMBER DESIGNATION

**KFH** - **632** - **8** **ET**

↓                      ↓                      ↓                      ↓

Type and      Thread      Length      Finish

Material      Code      Code      Code

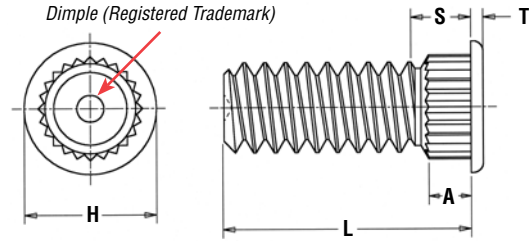

All dimensions are in inches.

| UNIFIED | Thread Size         | Type | Thread Code | Length "L" ±.010<br>(Length Code is in 16ths of an inch) |      |      |      |      | A<br>(Shank)<br>Max. | Min.<br>Sheet<br>Thickness | Hole<br>Size in<br>Sheet<br>+.003<br>-.000 | Max.<br>Hole<br>Size in<br>Attached<br>Parts | H<br>±.010 | S<br>Max.<br>(1) | T<br>±.005 | Min.<br>Dist.<br>Hole $\varnothing$<br>To<br>Edge |      |
|---------|---------------------|------|-------------|--|------|------|------|------|----------------------|----------------------------|--|--|------------|------------------|------------|---|------|
|         |                     |      |             | .250   | .312 | .375 | .500 | .625 |                      |                            |  |  |            |                  |            |   | .750 |
|         | .112-40<br>(#4-40)  | KFH  | 440         | 4  | 5    | 6    | 8    | 10   | 12                   | .065                       | .060                                       | .120   | .145       | .180             | .09        | .020  | .15  |
|         | .138-32<br>(#6-32)  | KFH  | 632         | 4  | 5    | 6    | 8    | 10   | 12                   | .065                       | .060                                       | .140   | .170       | .200             | .09        | .020  | .19  |
|         | .164-32<br>(#8-32)  | KFH  | 832         | 4  | 5    | 6    | 8    | 10   | 12                   | .065                       | .060                                       | .166   | .195       | .225             | .09        | .020  | .20  |
|         | .190-32<br>(#10-32) | KFH  | 032         | 4  | 5    | 6    | 8    | 10   | 12                   | .065                       | .060                                       | .189   | .220       | .250             | .09        | .020  | .20  |

All dimensions are in millimeters.

| METRIC | Thread Size x Pitch | Type | Thread Code | Length "L" ±0.25<br>(Length Code is in millimeters) |   |    |    |    | A<br>(Shank)<br>Max. | Min.<br>Sheet<br>Thickness | Hole<br>Size in<br>Sheet<br>+0.08 | Max.<br>Hole<br>Size in<br>Attached<br>Parts | H<br>±0.25 | S<br>Max.<br>(1) | T<br>±0.13 | Min.<br>Dist.<br>Hole $\varnothing$<br>To<br>Edge |     |
|--------|---------------------|------|-------------|---|---|----|----|----|----------------------|----------------------------|-----------------------------------|--|------------|------------------|------------|---|-----|
|        |                     |      |             | 6   | 8 | 10 | 12 | 15 |                      |                            |                                   |  |            |                  |            |   | 18  |
|        | M3 x 0.5            | KFH  | M3          | 6   | 8 | 10 | 12 | 15 | 18                   | 1.65                       | 1.53                              | 3  | 3.7        | 4.58             | 2.3        | 0.51  | 3.8 |
|        | M4 x 0.7            | KFH  | M4          | 6   | 8 | 10 | 12 | 15 | 18                   | 1.65                       | 1.53                              | 4.2  | 4.8        | 5.74             | 2.3        | 0.51  | 5.1 |
|        | M5 x 0.8            | KFH  | M5          | 6   | 8 | 10 | 12 | 15 | 18                   | 1.65                       | 1.53                              | 5  | 5.8        | 6.6              | 2.3        | 0.51  | 5.3 |

(1) Threads are gageable to within 2 pitches of the "S" Max. dimension. A class 3B/5H maximum material commercial nut shall pass up to the "S" Max. dimension.

# FASTENERS FOR USE WITH PC BOARDS

## ReelFast® SURFACE MOUNT RIGHT ANGLE (R'ANGLE®) FASTENERS



### PART NUMBER DESIGNATION

**SMTRA**   **256**   **- 8**   **- 6**   **ET**  
 ↓   ↓   ↓   ↓   ↓  
 Type   Thread Code   Height Code   Length Code   Finish Code



Patented.

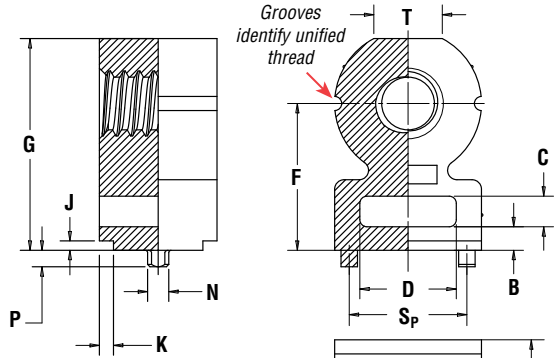
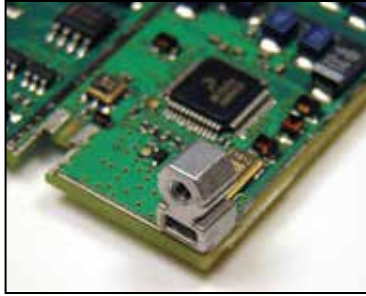

### Stencil Masking Examples

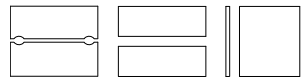

All dimensions are in inches.

| UNIFIED | Thread Size     | Type  | Thread Code | Height Code | Length Code | Length L<br>±.005 | Min. Sheet Thickness | Hole Size In Sheet<br>+.003 -.000 | A<br>±.006 | B<br>±.006 | C<br>±.006 | D<br>±.006 | Height F<br>±.006 | G<br>±.006 | J<br>Nom. | K<br>Nom. | N<br>Max. | P<br>Max. | S <sub>p</sub><br>±.003 | T<br>Nom. |
|---------|-----------------|-------|-------------|-------------|-------------|-------------------|----------------------|-----------------------------------|------------|------------|------------|------------|-------------------|------------|-----------|-----------|-----------|-----------|-------------------------|-----------|
|         | .086-56 (#2-56) | SMTRA | 256         | 8           | 6           | .188              | .040                 | .053                              | .218       | .040       | .060       | .140       | .250              | .345       | .020      | .030      | .048      | .040      | .157                    | .105      |
|         | .112-40 (#4-40) | SMTRA | 440         | 9           | 6           | .188              | .040                 | .053                              | .250       | .050       | .065       | .160       | .281              | .390       | .020      | .030      | .048      | .040      | .188                    | .125      |
|         | .138-32 (#6-32) | SMTRA | 632         | 10          | 8           | .250              | .040                 | .053                              | .312       | .050       | .065       | .205       | .312              | .450       | .020      | .030      | .048      | .040      | .250                    | .145      |
|         | .164-32 (#8-32) | SMTRA | 832         | 12          | 9           | .281              | .040                 | .053                              | .375       | .050       | .075       | .250       | .375              | .535       | .020      | .030      | .048      | .040      | .312                    | .195      |

All dimensions are in millimeters.

| METRIC | Thread Size x Pitch | Type  | Thread Code | Height Code | Length Code | Length L<br>±0.13 | Min. Sheet Thickness | Hole Size In Sheet<br>+0.08 | A<br>±0.15 | B<br>±0.15 | C<br>±0.15 | D<br>±0.15 | Height F<br>±0.15 | G<br>±0.15 | J<br>Nom. | K<br>Nom. | N<br>Max. | P<br>Max. | S <sub>p</sub><br>±0.08 | T<br>Nom. |
|--------|---------------------|-------|-------------|-------------|-------------|-------------------|----------------------|-----------------------------|------------|------------|------------|------------|-------------------|------------|-----------|-----------|-----------|-----------|-------------------------|-----------|
|        | M2 x 0.4            | SMTRA | M2          | 6           | 5           | 5                 | 1                    | 1.35                        | 5.5        | 1          | 1.5        | 3.5        | 6                 | 8.4        | 0.5       | 0.75      | 1.22      | 1         | 4                       | 2.65      |
|        | M2.5 x 0.45         | SMTRA | M25         | 6           | 5           | 5                 | 1                    | 1.35                        | 5.5        | 1          | 1.5        | 3.5        | 6                 | 8.4        | 0.5       | 0.75      | 1.22      | 1         | 4                       | 2.65      |
|        | M3 x 0.5            | SMTRA | M3          | 7           | 5           | 5                 | 1                    | 1.35                        | 6.35       | 1.25       | 1.65       | 4          | 7                 | 9.75       | 0.5       | 0.75      | 1.22      | 1         | 4.75                    | 3.2       |
|        | M4 x 0.7            | SMTRA | M4          | 9           | 7           | 7                 | 1                    | 1.35                        | 9.53       | 1.25       | 1.65       | 6.35       | 9                 | 13.1       | 0.5       | 0.75      | 1.22      | 1         | 7.9                     | 4.8       |

| UNIFIED | Thread Code | Pad Width P <sub>A</sub><br>Min. | Pad Length P <sub>L</sub><br>Min. | Hole Spacing S <sub>H</sub><br>±.002 | Hole Size In Sheet<br>+.003 -.000 |
|---------|-------------|----------------------------------|-----------------------------------|--------------------------------------|-----------------------------------|
|         | 256         | .262                             | .171                              | .157                                 | .053                              |
|         | 440         | .294                             | .171                              | .188                                 | .053                              |
|         | 632         | .356                             | .233                              | .250                                 | .053                              |
|         | 832         | .419                             | .264                              | .312                                 | .053                              |

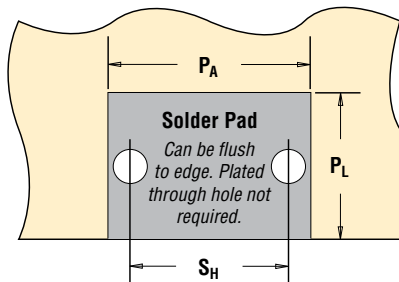

| METRIC | Thread Code | Pad Width P <sub>A</sub><br>Min. | Pad Length P <sub>L</sub><br>Min. | Hole Spacing S <sub>H</sub><br>±0.05 | Hole Size In Sheet<br>+0.08 |
|--------|-------------|----------------------------------|-----------------------------------|--------------------------------------|-----------------------------|
|        | M2          | 6.62                             | 4.57                              | 4                                    | 1.35                        |
|        | M25         | 6.62                             | 4.57                              | 4                                    | 1.35                        |
|        | M3          | 7.47                             | 4.57                              | 4.75                                 | 1.35                        |
|        | M4          | 10.65                            | 6.57                              | 7.9                                  | 1.35                        |

| Part Number   | Parts Per Reel | Pitch (mm) | Tape Width (mm) |
|---------------|----------------|------------|-----------------|
| SMTRA256-8-6  | 375            | 16         | 24              |
| SMTRA440-9-6  | 300            | 16         | 24              |
| SMTRA632-10-8 | 200            | 20         | 32              |
| SMTRA832-12-9 | 200            | 20         | 32              |
| SMTRAM2-6-5   | 375            | 16         | 24              |
| SMTRAM25-6-5  | 375            | 16         | 24              |
| SMTRAM3-7-5   | 300            | 16         | 24              |
| SMTRAM4-9-7   | 200            | 20         | 32              |





# FASTENERS FOR USE WITH PC BOARDS

## MATERIAL AND FINISH SPECIFICATIONS

| Type   | Threads (1)                            |  | Fastener Materials |                            |                         |               |                                  | Standard Finishes                      |  |           | Optional Finish | For Use in Sheet Hardness: (3) |                         |                         |                        |          |
|--|--|--|--------------------|----------------------------|-------------------------|---------------|----------------------------------|--|--|-----------|-----------------|--------------------------------|-------------------------|-------------------------|------------------------|----------|
|  | Internal, ASME B1.1 2B/ ASME B1.13M 6H | External, ASME B1.1 2A/ ASME B1.13M 6g | Carbon Steel       | 300 Series Stainless Steel | CDA-510 Phosphor Bronze | CDA-353 Brass | Nylon, Temp. Limit 200° F/ 93° C | Passivated and/or Tested Per ASTM A380 | Electro-Plated Tin ASTM B 545, Class B With Clear Preservative Coating, annealed (4) | No Finish | Black Nitride   | HRB 70 / HB 125 or Less        | HRB 65 / HB 116 or Less | HRB 60 / HB 107 or Less | HRB 55 / HB 96 or Less | PC Board |
| KF2  | •                                      |  | •                  |                            |                         |               |                                  | •                                      |  |           |                 |                                | •                       |                         | •                      |          |
| KFS2   | •                                      |  |                    | •                          |                         |               |                                  | •                                      |  |           |                 |                                |                         |                         | •                      |          |
| KFE  | •                                      |  | •                  |                            |                         |               |                                  | •                                      |  |           |                 |                                | •                       |                         | •                      |          |
| KFSE   | •                                      |  |                    | •                          |                         |               |                                  | •                                      |  |           |                 |                                |                         |                         | •                      |          |
| KFB3   | •                                      |  |                    |                            |                         |               | •                                | •                                      |  |           |                 |                                |                         |                         | •                      |          |
| KSSB   |  |  |                    |                            |                         |               | •                                |  |  |           |                 |                                |                         |                         | •                      |          |
| KFH  |  | •                                      |                    |                            | •                       |               |                                  | •                                      |  |           |                 |                                |                         |                         | •                      |          |
| PFK<br>Retainer<br>Screw<br>Spring<br>Retaining Ring |  |  |                    | •                          |                         |               |                                  | •                                      |  | •         |                 |                                |                         | •                       | •                      |          |
|  |  | •                                      |                    | •                          |                         |               |                                  | •                                      |  | •         |                 |                                |                         |                         |                        |          |
|  |  |  |                    | •                          |                         |               |                                  |  |  |           |                 |                                |                         |                         |                        |          |
|  |  |  |                    |                            |                         |               | •                                |  |  |           |                 |                                |                         |                         |                        |          |
| Part Number Codes For Finishes                       |  |  |                    |                            |                         |               | None                             | ET                                     | X  | BN        |                 |                                |                         |                         |                        |          |

| Type                           | Threads (1)             |  | Fastener Materials                     |              |       |                              |              | Standard Finishes (2)      |  |                                 | For Use in Sheet Hardness: (3) |                    |          |
|--------------------------------|-------------------------|--|--|--------------|-------|------------------------------|--------------|----------------------------|--|---------------------------------|--------------------------------|--------------------|----------|
|                                | Miniature ISO 1501, 4H6 | Internal, ASME B1.1 2B/ ASME B1.13M 6H | External, ASME B1.1 2A/ ASME B1.13M 6g | Carbon Steel | Brass | ABS Temp. Limit 200° F 93° C | Zinc Diecast | Zinc Plated 5µm, Colorless | Electro-Plated Tin ASTM B 545, Class A With Clear Preservative Coating, annealed (4) | Bright Nickel Over Copper Flash | HRB 80 / HB 150 or less        | Any Panel Hardness | PC Board |
| SMTSO                          | •<br>S1 to S1.4         | •<br>0-80 to 8-32<br>M1.6 to M4        |  | •            |       |                              |              |                            | •  |                                 |                                |                    | •        |
| SMTSOB                         |                         | •                                      |  |              |       |                              |              | •                          |  |                                 |                                |                    | •        |
| SMTRA                          |                         | •                                      |  |              |       |                              | •            |                            | •  |                                 |                                |                    | •        |
| SMTPR                          |                         |  |  | •            |       |                              |              |                            | •  |                                 |                                |                    | •        |
| PSHP<br>Cap<br>Screw           |                         |  |  |              |       | •                            |              |                            |  |                                 |                                |                    |          |
|                                |                         |  |  | •            | •     |                              |              |                            |  | •                               |                                |                    |          |
| SFK                            |                         |  |  | •            |       |                              |              | •                          |  |                                 |                                | •                  | •        |
| Part Number Codes For Finishes |                         |  |  |              |       |                              |              | ZI                         | ET   | CN                              |                                |                    |          |

- (1) For plated studs, Class 2A/6g, the maximum major and pitch diameter, after plating, may equal basic sizes and can be gauged to Class 3A/6h, per ASME B1.1 (see notes at end of table C-1) and ASME B1.13M, Section 8, Paragraph 8.2.
- (2) See PEM Technical Support section of our web site for related plating standards and specifications.
- (3) HRB - Hardness Rockwell "B" Scale. HB - Hardness Brinell.
- (4) Optimal solderability life noted on packaging.

# FASTENERS FOR USE WITH PC BOARDS

## INSTALLATION

### For Types KF2/KFS2/KFE/KFSE/PFK

1. Prepare properly sized mounting hole in board.
2. Place fastener into the anvil hole and place the mounting hole over the shank of the fastener as shown in drawing.
3. With installation punch and anvil surfaces parallel, apply squeezing force until shoulder contacts the board.

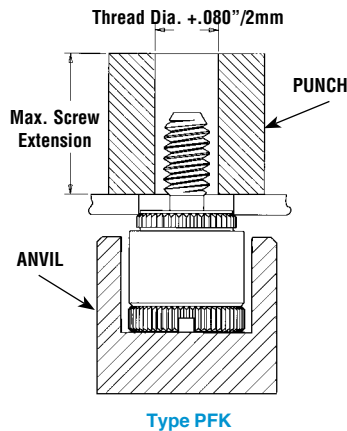

### PEMSERTER® Installation Tooling

| Type | Thread Code | Anvil Part Number | Punch Part Number |
|------|-------------|-------------------|-------------------|
| PFK  | 440/M3      | 975200026         | 975200060         |
| PFK  | 632         | 975200027         | 975200061         |

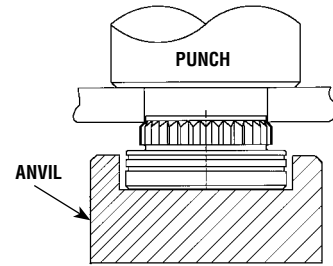

Types KF2/KFS2/  
KFE/KFSE

### PEMSERTER® Installation Tooling

| Type     | Thread Code        | Anvil Part Number | Punch Part Number |
|----------|--------------------|-------------------|-------------------|
| KF2/KFS2 | 080                | 8015899           |                   |
| KF2/KFS2 | 256/440/M2/M2.5/M3 | 975200904300      | 975200048         |
| KF2/KFS2 | 632/M3.5           | 975200035         |                   |
| KF2/KFS2 | 832/M4             | 975200037         |                   |
| KF2/KFS2 | 032/M5             | 975200905300      |                   |

### PEMSERTER® Installation Tooling

| Type     | Thread Code        | Anvil Part Number | Punch Part Number |
|----------|--------------------|-------------------|-------------------|
| KFE/KFSE | 440/116 -4 to -8   | 975200846300      | 975200048         |
| KFE/KFSE | 440/116 -10 to -12 | 975200847300      |                   |
| KFE/KFSE | 440/116 -16 to -20 | 975200848300      |                   |
| KFE/KFSE | 440/116 -20 to -24 | 975200882300      |                   |
| KFE/KFSE | M3 -3 to -6        | 975200846300      |                   |
| KFE/KFSE | M3 -8 to -10       | 975200847300      |                   |
| KFE/KFSE | M3 -12 to -14      | 975201222300      |                   |
| KFE/KFSE | M3 -14 to -16      | 975200848300      |                   |
| KFE/KFSE | 632/143 -4 to -8   | 975200849300      |                   |
| KFE/KFSE | 632/143 -10 to -12 | 975200850300      |                   |
| KFE/KFSE | 632/143 -16 to -20 | 975200851300      | 975200048         |
| KFE/KFSE | 632/143 -22 to -24 | 975200883300      |                   |
| KFE/KFSE | 632/143 -28 to -32 | 975200884300      |                   |
| KFE/KFSE | 3.6 -3 to -6       | 975200849300      |                   |
| KFE/KFSE | 3.6 -8 to -10      | 975200850300      |                   |
| KFE/KFSE | 3.6 -12 to -16     | 975200851300      |                   |
| KFE/KFSE | 4.2 -2             | 975201216300      |                   |
| KFE/KFSE | 4.2 -3 to -6       | 975201217300      |                   |
| KFE/KFSE | 4.2 -8 to -10      | 975201218300      |                   |
| KFE/KFSE | 4.2 -12 to -14     | 975201220300      |                   |
| KFE/KFSE | 4.2 -14 to -16     | 975201219300      |                   |

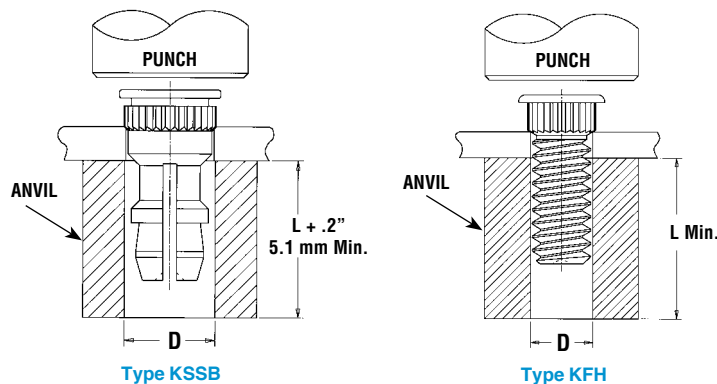

### For Types KSSB/KFH

1. Prepare properly sized mounting hole in board.
2. Place fastener into mounting hole as shown in drawing.
3. With installation punch and anvil surfaces parallel, apply squeezing force until head contacts the board.

| Part Number | D<br>+.003" -.000" |
|-------------|--------------------|
| KFH-440-L   | .113"              |
| KFH-632-L   | .140"              |
| KFH-832-L   | .166"              |
| KFH-032-L   | .191"              |
| KSSB-156-L  | .216"              |

| Part Number | D<br>+0.08mm |
|-------------|--------------|
| KFH-M3-L    | 3.1mm        |
| KFH-M4-L    | 4.1mm        |
| KFH-M5-L    | 5.1mm        |
| KSSB-4mm-L  | 5.49mm       |

# FASTENERS FOR USE WITH PC BOARDS

## For Type KFB3<sup>(1)</sup>

1. Punch or drill properly sized round mounting hole in board.
2. Place fastener into the anvil hole and place the mounting hole over the shank of the fastener as shown in diagram to the left.
3. Using a punch flaring tool and a recessed anvil, apply squeezing force until the shoulder of the fastener contacts the board. As the fastener seats itself in the proper position, the punch tool will flare the extended portion of the shank outward to complete the installation. The combination of broaching and flaring provides high pushout performance.

(1) PennEngineering manufactures and stocks the installation tooling for the KFB3.

| Thread Code | Length Code | Anvil        | Punch (Flaring Tool) |
|-------------|-------------|--------------|----------------------|
| #4-40       | -2          | 975201213300 | 975201231400         |
| #4-40       | -4 to -8    | 975200846300 |                      |
| #4-40       | -10 to -12  | 975200847300 |                      |
| #4-40       | -16 to -20  | 975200848300 |                      |
| #4-40       | -20 to -24  | 975200882300 |                      |
| #6-32       | -2          | 975201215300 | 975201232400         |
| #6-32       | -4 to -8    | 975200849300 |                      |
| #6-32       | -10 to -12  | 975200850300 |                      |
| #6-32       | -16 to -20  | 975200851300 |                      |
| #6-32       | -22 to -24  | 975200883300 |                      |
| #6-32       | -28 to -32  | 975200884300 |                      |

| Thread Code | Length Code | Anvil        | Punch (Flaring Tool) |
|-------------|-------------|--------------|----------------------|
| M3          | -2          | 975201213300 | 975201231400         |
| M3          | -3 to -6    | 975200846300 |                      |
| M3          | -8 to -10   | 975200847300 |                      |
| M3          | -12 to -14  | 975201222300 |                      |
| M3          | -14 to -16  | 975200848300 |                      |
| M4          | -2          | 975201216300 | 975201221400         |
| M4          | -3 to -6    | 975201217300 |                      |
| M4          | -8 to -10   | 975201218300 |                      |
| M4          | -12 to -14  | 975201220300 |                      |
| M4          | -14 to -16  | 975201219300 |                      |

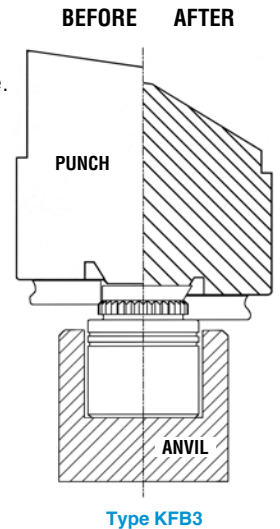

# FASTENERS FOR USE WITH PC BOARDS

## INSTALLATION

### For Type SFK

- Step 1.** Prepare properly sized mounting hole in both panels.
- Step 2.** Using only Panel 1, with the punch and anvil surfaces parallel, apply squeezing force until the fastener is flush with the top of Panel 1.
- Step 3.** Place Panel 2 over fastener and apply squeezing force.

### ANVIL DIMENSIONS

| Size  | C<br>±0.13/±.003<br>(mm) / (in.) | Punch<br>Part No. | Anvil<br>Part No.* |
|-------|----------------------------------|-------------------|--------------------|
| SFK-3 | 3.05 / .120                      | 975200048         | 970200229300       |
| SFK-5 | 5.05 / .199                      | 975200048         | 970200020300       |

\* Part number for anvil used in Step 2

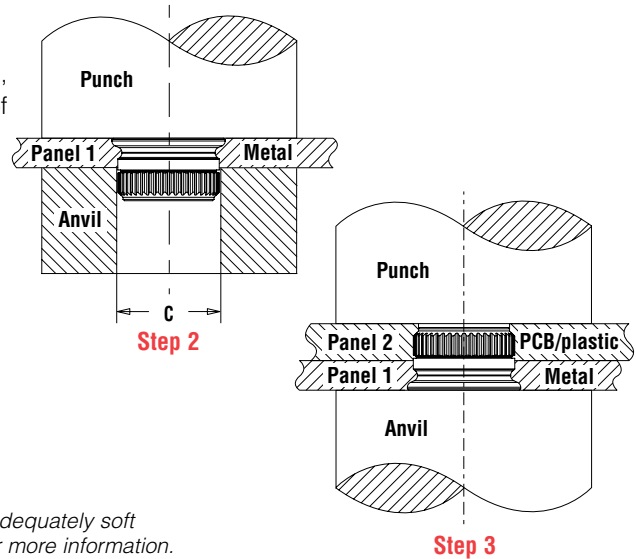

**NOTE:** Fastener can be installed in both sheets at once when metal panel is adequately soft compared to the non-metal panel. E-mail [techsupport@pemnet.com](mailto:techsupport@pemnet.com) for more information.

### For SMT Nuts and Standoffs

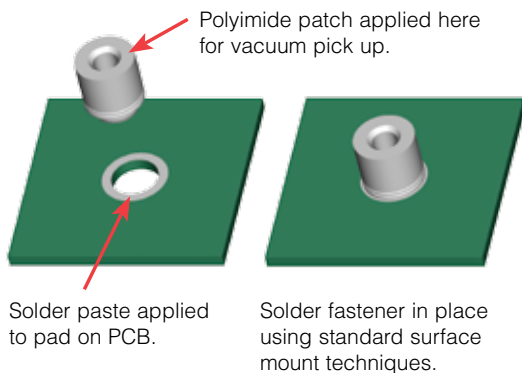

### For SMT R'ANGLE® Fasteners

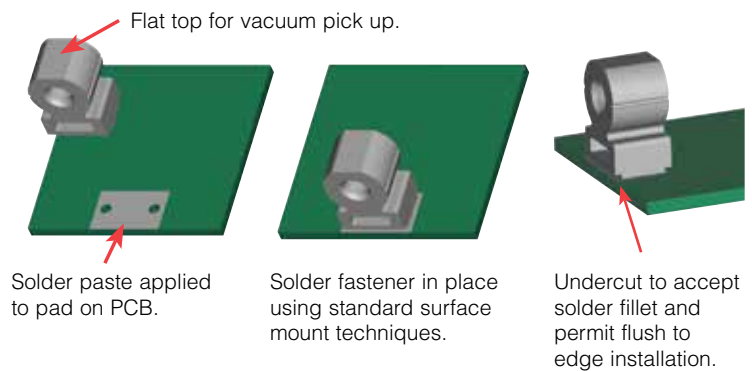

### For SMT Captive Panel Screws

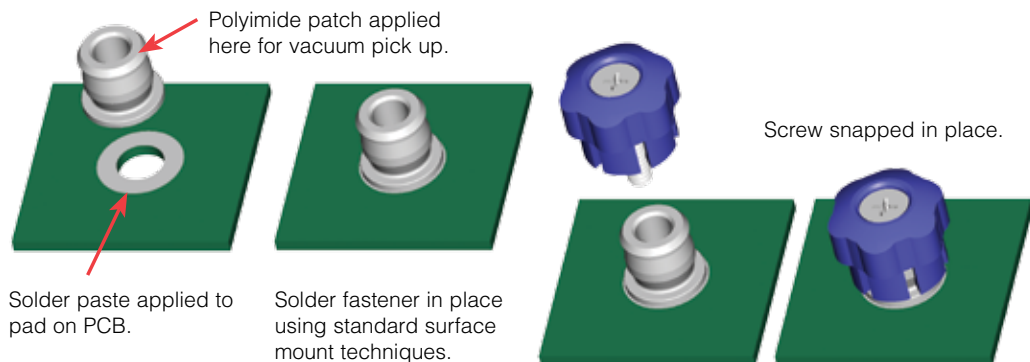

# FASTENERS FOR USE WITH PC BOARDS

## PERFORMANCE DATA<sup>(1)</sup>

### TYPES KF2/KFS2/KFE/KFSE/KFB3/KFH/PFK BROACHING AND BROACH/FLARE MOUNT FASTENERS

| UNIFIED | Type | Thread Code | Max. Nut Tightening Torque (in. lbs.) | Test Sheet Thickness & Test Sheet Material | Installation (lbs.) | Pushout (lbs.) (2) | Torque-out (in. lbs.) |
|---------|------|-------------|---------------------------------------|--|---------------------|--------------------|-----------------------|
|         | KF2  | 256         | (3)                                   | .060" FR-4 Panel                           | 400                 | 60                 | 6                     |
|         |      | 440         | (3)                                   | .060" FR-4 Panel                           | 400                 | 65                 | 15                    |
|         | KFS2 | 632         | (3)                                   | .060" FR-4 Panel                           | 500                 | 80                 | 30                    |
|         |      | 832         | (3)                                   | .060" FR-4 Panel                           | 700                 | 95                 | 35                    |
|         | KFSE | 032         | (3)                                   | .060" FR-4 Panel                           | 700                 | 100                | 40                    |
|         |      | KFB3        | 440                                   | (3)  | .060" FR-4 Panel    | 1,000              | 140                   |
|         | 632  |             | (3)                                   | .060" FR-4 Panel                           | 1,500               | 170                | 28                    |
|         | KFH  | 440         | 4                                     | .060" FR-4 Panel                           | 400                 | 65                 | 7                     |
|         |      | 632         | 8                                     | .060" FR-4 Panel                           | 400                 | 70                 | 11                    |
| 832     |      | 15          | .060" FR-4 Panel                      | 400  | 80                  | 16                 |                       |
| 032     |      | 18          | .060" FR-4 Panel                      | 400  | 90                  | 17                 |                       |
| PFK     | 440  | (3)         | .060" FR-4 Panel                      | 250  | 55                  | (3)                |                       |
|         | 632  | (3)         | .060" FR-4 Panel                      | 400  | 60                  | (3)                |                       |

| METRIC | Type                       | Thread Code | Max. Nut Tightening Torque (N•m) | Test Sheet Thickness & Test Sheet Material | Installation (kN) | Pushout (N) (2) | Torque-out (N•m) |
|--------|----------------------------|-------------|----------------------------------|--|-------------------|-----------------|------------------|
|        | KF2<br>KFS2<br>KFE<br>KFSE | M3          | (3)                              | 1.5 mm FR-4 Panel                          | 2.2               | 290             | 1.7              |
|        |                            | M4          | (3)                              | 1.5 mm FR-4 Panel                          | 2.2               | 420             | 3.4              |
|        |                            | M5          | (3)                              | 1.5 mm FR-4 Panel                          | 2.9               | 440             | 4.5              |
|        | KFB3                       | M3          | (3)                              | 1.5 mm FR-4 Panel                          | 4.4               | 560             | 2.03             |
|        |                            | M4          | (3)                              | 1.5 mm FR-4 Panel                          | 6                 | 680             | 3.2              |
|        | KFH                        | M3          | 0.45                             | 1.5 mm FR-4 Panel                          | 1.8               | 285             | 0.79             |
|        |                            | M4          | 1.6                              | 1.5 mm FR-4 Panel                          | 1.8               | 355             | 1.8              |
|        |                            | M5          | 2.1                              | 1.5 mm FR-4 Panel                          | 1.8               | 400             | 1.92             |
|        | PFK                        | M3          | (3)                              | 1.5 mm FR-4 Panel                          | 1.1               | 245             | (3)              |

### TYPE KSSB BROACHING SNAP-TOP® STANDOFFS

| UNIFIED | Type | Panel 1 (.060" FR-4 Panel) (4) |                | Panel 2 (Removable) (4)    |                             |                            |
|---------|------|--------------------------------|----------------|----------------------------|-----------------------------|----------------------------|
|         |      | Installation (lbs.)            | Pushout (lbs.) | Max. First On Force (lbs.) | Min. First Off Force (lbs.) | Min. 15th Off Force (lbs.) |
|         | KSSB | 500                            | 110            | 13                         | 3.0                         | 1.0                        |

| METRIC | Type | Panel 1 (1.5 mm FR-4 Panel) (4) |             | Panel 2 (Removable) (4) |                          |                         |
|--------|------|---------------------------------|-------------|-------------------------|--------------------------|-------------------------|
|        |      | Installation (kN)               | Pushout (N) | Max. First On Force (N) | Min. First Off Force (N) | Min. 15th Off Force (N) |
|        | KSSB | 2.2                             | 484         | 57.7                    | 13.3                     | 4.4                     |

(1) Published installation forces are for general reference. Actual set-up and confirmation of complete installation should be made by observing proper seating of fastener as described in the installation steps. Other performance values reported are averages when all proper installation parameters and procedures are followed. Variations in mounting hole size, sheet material, and installation procedure may affect performance. Performance testing this product in your application is recommended. We will be happy to provide technical assistance and/or samples for this purpose.

(2) These are typical values for parts installed in drilled mounting holes. Punched mounting holes yield values approximately 15% less.

(3) Not applicable.

(4) See Application Data drawing on page 7.

#### PEMSERTER® PRESSES

For best results we recommend using a PEMSERTER® press for installation of PEM broaching fasteners. For more information on our line of presses check our web site.



# FASTENERS FOR USE WITH PC BOARDS

## PERFORMANCE DATA<sup>(1)</sup>

### TYPE SFK SpotFast® CLINCH/BROACH MOUNT FASTENERS

| Type and Size | Thickness Code | Installation into Panel 1 |      | Installation into Panel 2 |      | Pushout of Panel 2 <sup>(2)</sup> |      |
|---------------|----------------|---------------------------|------|---------------------------|------|-----------------------------------|------|
|               |                | Cold-rolled Steel         |      | FR-4 Fiberglass           |      | N                                 | lbs. |
|               |                | kN                        | lbs. | kN                        | lbs. |                                   |      |
| SFK-3         | 0.8            | 6.2                       | 1400 | 1.8                       | 400  | 200                               | 45   |
| SFK-3         | 1.0            | 8                         | 1800 | 1.8                       | 400  | 200                               | 45   |
| SFK-3         | 1.2            | 8.9                       | 2000 | 1.8                       | 400  | 200                               | 45   |
| SFK-3         | 1.6            | 10.2                      | 2300 | 1.8                       | 400  | 200                               | 45   |
| SFK-5         | 0.8            | 11.1                      | 2500 | 1.8                       | 400  | 400                               | 90   |
| SFK-5         | 1.0            | 13.5                      | 3000 | 1.8                       | 400  | 400                               | 90   |
| SFK-5         | 1.2            | 15.6                      | 3500 | 1.8                       | 400  | 400                               | 90   |
| SFK-5         | 1.6            | 17.8                      | 4000 | 1.8                       | 400  | 400                               | 90   |

(1) Published installation forces are for general reference. Actual set-up and confirmation of complete installation should be made by observing proper seating of fastener as described in the installation steps. Other performance values reported are averages when all proper installation parameters and procedures are followed. Variations in mounting hole size, sheet material, and installation procedure may affect performance. Performance testing this product in your application is recommended. We will be happy to provide technical assistance and/or samples for this purpose.

(2) In most applications, pullout strength of the SFK fastener in Panel 1 exceeds pushout strength of Panel 2.

### TYPE SMTSO NUTS AND SPACERS/STANDOFFS<sup>(3)(4)</sup>

| Type and Size | Test Sheet Material     |             |                       |                  |
|---------------|-------------------------|-------------|-----------------------|------------------|
|               | .062" Single Layer RF-4 |             |                       |                  |
|               | Pushout (lbs.)          | Pushout (N) | Torque-out (in. lbs.) | Torque-out (N•m) |
| SMTSO-440     | 56.5                    | 251         | 8.56                  | 1                |
| SMTSO-632     | 93.5                    | 416         | 13.83                 | 1.6              |
| SMTSO-832     | 151.1                   | 672         | 26.96                 | 3                |
| SMTSO-M3      | 56.5                    | 251         | 8.56                  | 1                |
| SMTSO-M3.5    | 93.5                    | 416         | 13.83                 | 1.6              |
| SMTSO-M4      | 151.1                   | 672         | 26.96                 | 3                |

### TYPE SMTSO microPEM® FASTENERS<sup>(3)(4)</sup>

| Type and Size | Test Sheet Material     |             |                       |                  |
|---------------|-------------------------|-------------|-----------------------|------------------|
|               | .062" Single Layer RF-4 |             |                       |                  |
|               | Pushout (lbs.)          | Pushout (N) | Torque-out (in. lbs.) | Torque-out (N•m) |
| SMTSO-080     | 85.1                    | 378.7       | 4.94                  | 0.56             |
| SMTSO-M1      |                         |             |                       |                  |
| SMTSO-M1.2    |                         |             |                       |                  |
| SMTSO-M1.4    |                         |             |                       |                  |
| SMTSO-M1.6    |                         |             |                       |                  |

### TYPE SMTRA R'ANGLE® FASTENERS WITH ET FINISH<sup>(3)(4)</sup>

| UNIFIED | Part Number   | Test Sheet Material     |                  |
|---------|---------------|-------------------------|------------------|
|         |               | .062" Single Layer FR-4 |                  |
|         |               | Pushout (lbs.)          | Side Load (lbs.) |
|         | SMTRA256-8-6  | 51.7                    | 7.1              |
|         | SMTRA440-9-6  | 89.5                    | 10.8             |
|         | SMTRA632-10-8 | 110.3                   | 8.4              |
|         | SMTRA832-12-9 | 137.2                   | 21.2             |

| METRIC | Part Number  | Test Sheet Material      |               |
|--------|--------------|--------------------------|---------------|
|        |              | 1.58mm Single Layer FR-4 |               |
|        |              | Pushout (N)              | Side Load (N) |
|        | SMTRAM2-6-5  | 418.2                    | 56.8          |
|        | SMTRAM25-6-5 | 216.5                    | 36.9          |
|        | SMTRAM3-7-5  | 257.6                    | 41.3          |
|        | SMTRAM4-9-7  | 369.3                    | 73.3          |

### TYPE SMTPR RETAINERS<sup>(3)</sup>

| Part Number | Test Sheet Material     |             |
|-------------|-------------------------|-------------|
|             | .062" Single Layer RF-4 |             |
|             | Pushout (lbs.)          | Pushout (N) |
| SMTPR-6-1ET | 161.4                   | 718         |

## TESTING CONDITIONS

**Oven** Quad ZCR convection oven with 4 zones  
**High Temp** 518°F / 270°C  
**Board Finish** 62% Sn, 38% Pb  
**Screen Printer** Ragin Manual Printer

**Vias** None  
**Spokes** 2 Spoke Pattern  
**Paste (lead-free)** Amtech NC559LF Sn96.5/3.0Ag/0.5Cu (SAC305)  
**Stencil** .0067" / 0.17 mm thick

(3) With lead-free paste. Average values of 30 test points. The data presented here is for general comparison purposes only. Actual performance is dependent upon application variables. We will be happy to provide samples for you to install. If required, we can also test your installed hardware and provide you with the performance data specific to your application.

(4) Further testing details can be found in our website's literature section.

# FASTENERS FOR USE WITH PC BOARDS

## OTHER FASTENERS FOR CONSIDERATION TO USE WITH PC BOARDS

### TYPE PF11MW™ FLOATING CAPTIVE PANEL SCREWS

(See PEM® Bulletin PF)

Unique flare mount feature allow fasteners to “float” in mounting hole.

- Compensates for mating thread misalignment.
- Installs into any panel material.
- Appropriate for close center-line-to-edge applications.
- Color coded knobs available.

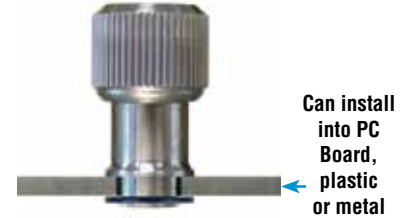

### TYPE PF11MF™ FLARE-MOUNTED CAPTIVE PANEL SCREWS

(See PEM® Bulletin PF)

- Appropriate for close centerline-to-edge applications.
- Doesn't require high installation force.
- Installs into any panel material.
- Installs flush on back side of panel.
- Color coded knobs available.



### TYPE SOAG/SOSG GROUNDING STANDOFFS

(See PEM® Bulletin SO)

- Designed for clinching into steel or aluminum chassis.
- “Gripping teeth” on opposite side of standoff makes firm electrical contact with mating PC Board.

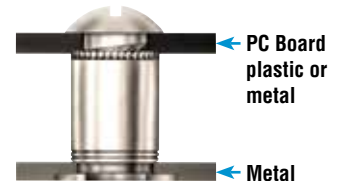

### TYPE SKC KEYHOLE® STANDOFFS

(See PEM® Bulletin SK)

- Clinch feature mounts fastener permanently into metal sheet.
- Allows for quick attachment and detachment of PC Board.
- Head is flush or sub-flush in metal sheet.
- Makes horizontal or vertical component mounting possible.

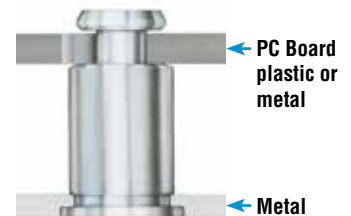

### TYPE SSA/SSC/SSS SNAP-TOP® STANDOFFS

(See PEM® Bulletin SSA)

- Spring action holds PC Boards and subassemblies securely, while allowing for quick removal.
- Screws and other threaded hardware are eliminated.

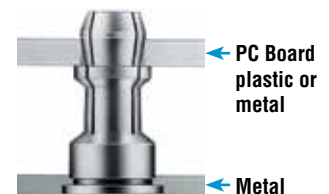

# FASTENERS FOR USE WITH PC BOARDS

## PEM® TRADEMARKS

For more information on these and other PEM products, visit our PEMNET™ Resource Center at [www.pemnet.com](http://www.pemnet.com)



Regulatory compliance information is available in Technical Support section of our website. © 2015 PennEngineering.

Specifications subject to change without notice. See our website for the most current version of this bulletin.

**PennEngineering®**



**North America:** Danboro, PA USA • E-mail: [info@pemnet.com](mailto:info@pemnet.com) • Tel: +1-215-766-8853 • Fax: +1-215-766-0143 • 800-237-4736 (USA Only)  
**Europe:** Galway, Ireland • E-mail: [europe@pemnet.com](mailto:europe@pemnet.com) • Tel: +353-91-751714 • Fax: +353-91-753541  
**Asia/Pacific:** Singapore • E-mail: [singapore@pemnet.com](mailto:singapore@pemnet.com) • Tel: +65-6-745-0660 • Fax: +65-6-745-2400  
Shanghai, China • E-mail: [china@pemnet.com](mailto:china@pemnet.com) • Tel: +86-21-5868-3688 • Fax: +86-21-5868-3988

Visit our PEMNET™ Resource Center at [www.pemnet.com](http://www.pemnet.com)

Technical support e-mail: [techsupport@pemnet.com](mailto:techsupport@pemnet.com)